

**Qty. Description**

1 CRN 5-9 A-P-A-E-HQQE



Product No.: [96517246](#)

Vertical, multistage centrifugal pump with inlet and outlet ports on same the level (inline). Pump materials in contact with the liquid are in high-grade stainless steel. A cartridge shaft seal ensures high reliability, safe handling, and easy access and service. Power transmission is via a rigid split coupling. Pipe connection is via PJE (Victaulic®) couplings.

The pump is fitted with a 3-phase, fan-cooled asynchronous motor.

**Controls:**

Frequency converter: NONE

**Liquid:**

Pumped liquid: Water  
 Liquid temperature range: -20 .. 120 °C  
 Liquid temperature during operation: 20 °C  
 Density: 998.2 kg/m<sup>3</sup>

**Technical:**

Pump speed on which pump data are based: 2896 rpm  
 Rated flow: 5.8 m<sup>3</sup>/h  
 Rated head: 47.7 m  
 Pump orientation: Vertical  
 Shaft seal arrangement: Single  
 Code for shaft seal: HQQE  
 Approvals on nameplate: CE, EAC, ACS  
 Curve tolerance: ISO9906:2012 3B

**Materials:**

Base: Stainless steel  
 EN 1.4408  
 AISI 316  
 Impeller: Stainless steel  
 EN 1.4401  
 AISI 316  
 Bearing: SIC

**Installation:**

Maximum ambient temperature: 60 °C  
 Maximum operating pressure: 25 bar  
 Max pressure at stated temp: 25 bar / 120 °C  
 25 bar / -20 °C  
 Type of connection: PJE  
 Size of inlet connection: DN 32  
 1 1/4 inch  
 Size of outlet connection: DN 32  
 1 1/4 inch  
 Pressure rating for pipe connection: PN 50  
 Flange size for motor: FT115

**Qty. Description****Electrical data:**

Motor standard:	IEC
Motor type:	90SB
IE Efficiency class:	IE3
Rated power - P2:	1.5 kW
Power (P2) required by pump:	1.5 kW
Mains frequency:	50 Hz
Rated voltage:	3 x 220-240D/380-415Y V
Rated current:	5.45/3.15 A
Starting current:	850-930 %
Cos phi - power factor:	0.87-0.82
Rated speed:	2890-2910 rpm
Efficiency:	IE3 84,2%
Motor efficiency at full load:	84.2 %
Motor efficiency at 3/4 load:	84.5 %
Motor efficiency at 1/2 load:	83.1 %
Number of poles:	2
Enclosure class (IEC 34-5):	55 Dust/Jetting
Insulation class (IEC 85):	F

**Others:**

Minimum efficiency index, MEI $\hat{\alpha}\%$ :	0.57
Net weight:	33.2 kg
Gross weight:	37.2 kg
Shipping volume:	0.092 m <sup>3</sup>
Danish VVS No.:	385912009
Norwegian NRF no.:	9040478
Country of origin:	HU
Custom tariff no.:	84137075

## 96517246 CRN 5-9 A-P-A-E-HQQE 50 Hz

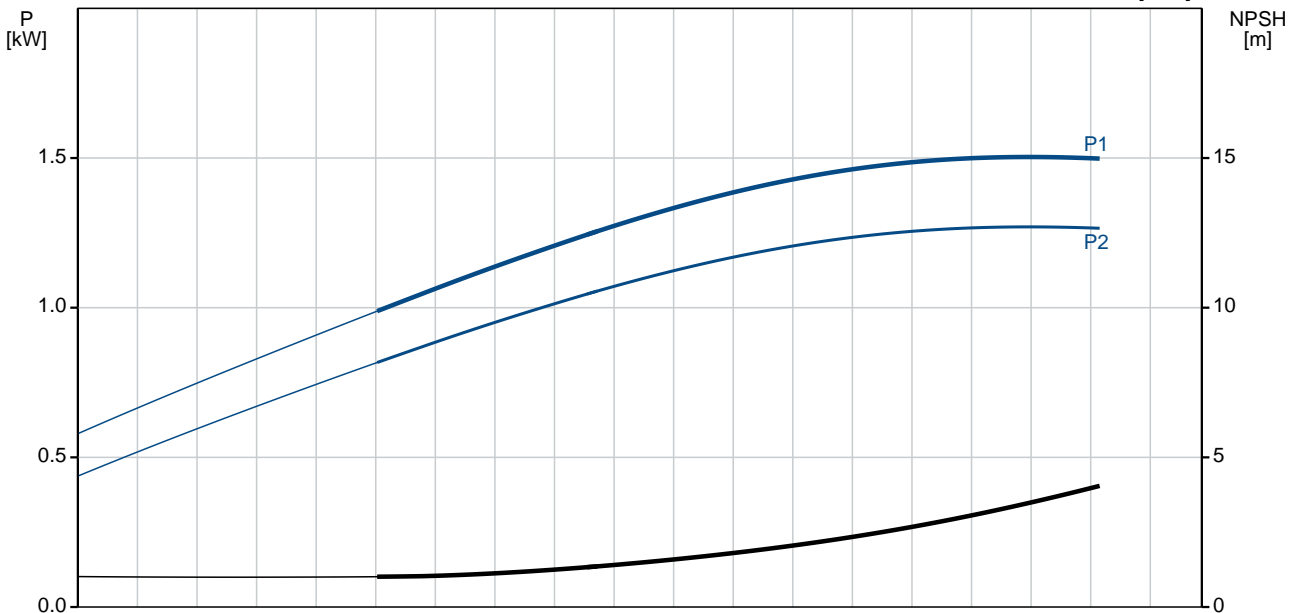
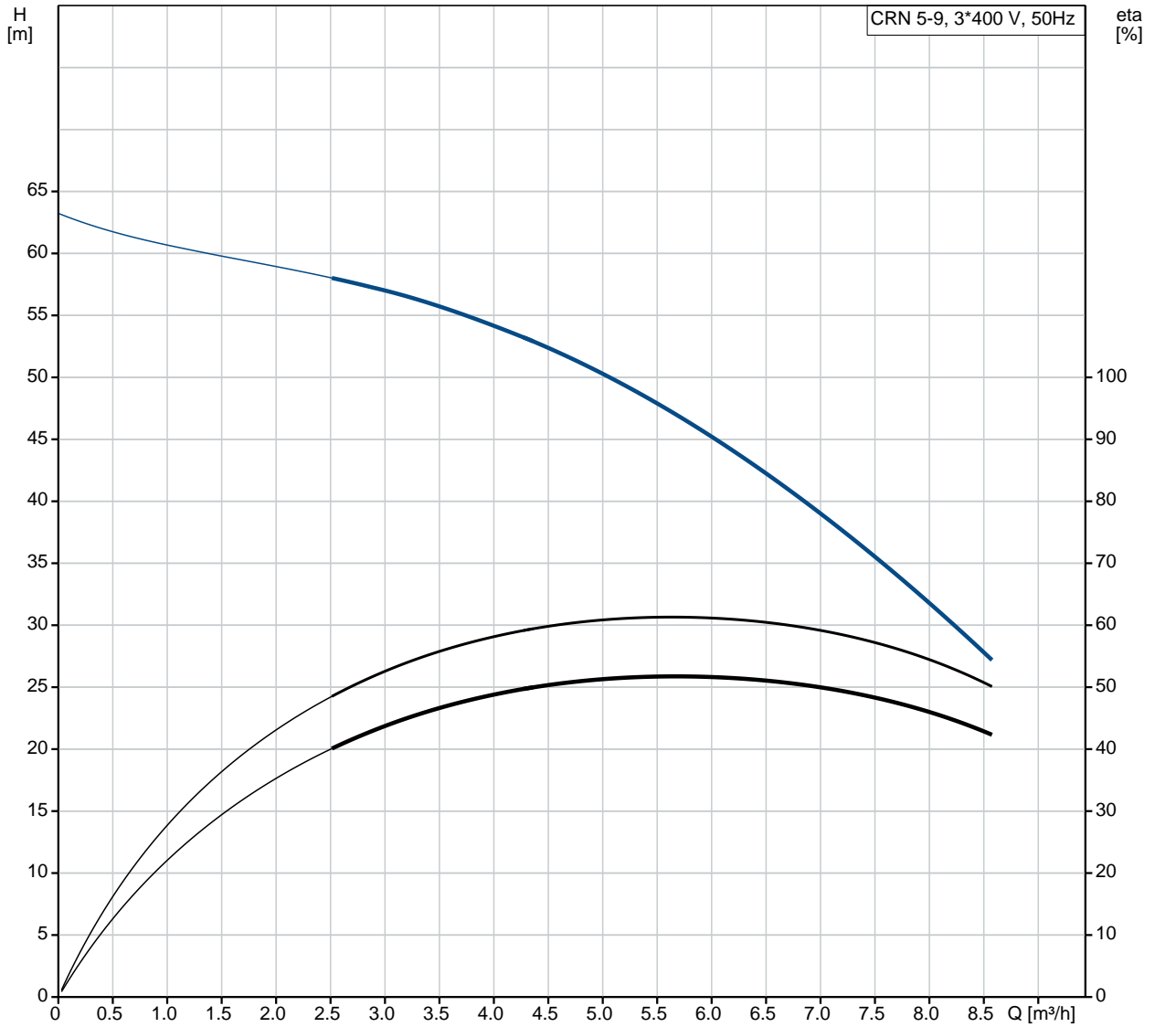

Description	Value
<b>General information:</b>	
Product name:	CRN 5-9 A-P-A-E-HQQE
Product No:	96517246
EAN number:	5700396759104
Price:	1.242,00 GBP
<b>Technical:</b>	
Pump speed on which pump data are based:	2896 rpm
Rated flow:	5.8 m <sup>3</sup> /h
Rated head:	47.7 m
Head max:	63.9 m
Stages:	9
Impellers:	9
Number of reduced-diameter impellers:	0
Low NPSH:	N
Pump orientation:	Vertical
Shaft seal arrangement:	Single
Code for shaft seal:	HQQE
Approvals on nameplate:	CE, EAC, ACS
Curve tolerance:	ISO9906:2012 3B
Pump version:	A
Model:	A
<b>Materials:</b>	
Base:	Stainless steel EN 1.4408 AISI 316
Impeller:	Stainless steel EN 1.4401 AISI 316
Material code:	A
Code for rubber:	E
Bearing:	SIC
<b>Installation:</b>	
Maximum ambient temperature:	60 °C
Maximum operating pressure:	25 bar
Max pressure at stated temp:	25 bar / 120 °C 25 bar / -20 °C
Type of connection:	PJE
Size of inlet connection:	DN 32 1 1/4 inch
Size of outlet connection:	DN 32 1 1/4 inch
Pressure rating for pipe connection:	PN 50
Flange size for motor:	FT115
Connect code:	P
<b>Liquid:</b>	
Pumped liquid:	Water
Liquid temperature range:	-20 .. 120 °C
Liquid temperature during operation:	20 °C
Density:	998.2 kg/m <sup>3</sup>
<b>Electrical data:</b>	
Motor standard:	IEC
Motor type:	90SB
IE Efficiency class:	IE3
Rated power - P2:	1.5 kW
Power (P2) required by pump:	1.5 kW
Mains frequency:	50 Hz

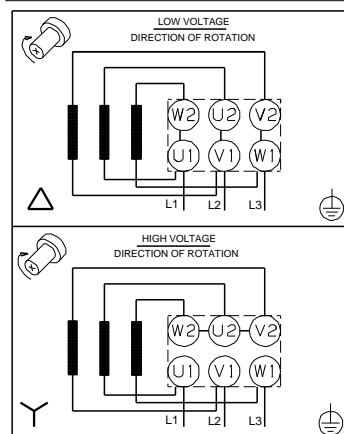
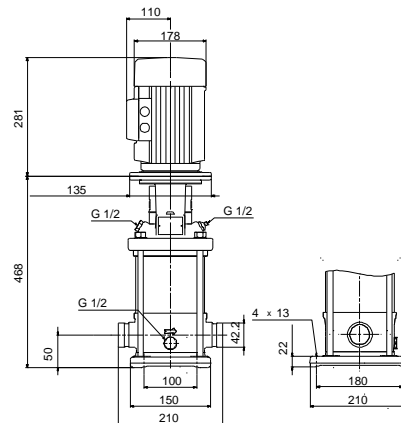
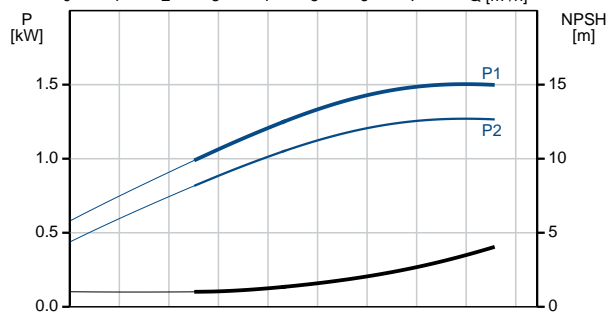
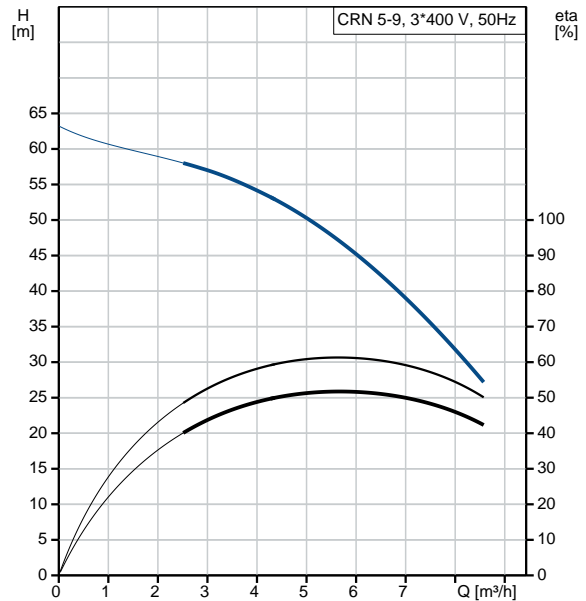

Description	Value
Rated voltage:	3 x 220-240D/380-415Y V
Rated current:	5.45/3.15 A
Starting current:	850-930 %
Cos phi - power factor:	0.87-0.82
Rated speed:	2890-2910 rpm
Efficiency:	IE3 84,2%
Motor efficiency at full load:	84.2 %
Motor efficiency at 3/4 load:	84.5 %
Motor efficiency at 1/2 load:	83.1 %
Number of poles:	2
Enclosure class (IEC 34-5):	55 Dust/Jetting
Insulation class (IEC 85):	F
Motor protec:	NONE
Motor No:	85U05906
<b>Controls:</b>	
Frequency converter:	NONE
<b>Others:</b>	
Minimum efficiency index, MEI $\hat{a}\%$ ¥:	0.57
Net weight:	33.2 kg
Gross weight:	37.2 kg
Shipping volume:	0.092 m <sup>3</sup>
Danish VVS No.:	385912009
Norwegian NRF no.:	9040478
Country of origin:	HU
Custom tariff no.:	84137075

## 96517246 CRN 5-9 A-P-A-E-HQQE 50 Hz

