

**Qty. Description**

1 CRN 3-8 A-P-A-E-HQQE



Product No.: [96516901](#)

Vertical, multistage centrifugal pump with inlet and outlet ports on same the level (inline). Pump materials in contact with the liquid are in high-grade stainless steel. A cartridge shaft seal ensures high reliability, safe handling, and easy access and service. Power transmission is via a rigid split coupling. Pipe connection is via PJE (Victaulic®) couplings.

The pump is fitted with a 3-phase, fan-cooled asynchronous motor.

**Controls:**

Frequency converter: NONE

**Liquid:**

Pumped liquid: Water  
 Liquid temperature range: -20 .. 120 °C  
 Liquid temperature during operation: 20 °C  
 Density: 998.2 kg/m<sup>3</sup>

**Technical:**

Pump speed on which pump data are based: 2864 rpm  
 Rated flow: 3 m<sup>3</sup>/h  
 Rated head: 38.3 m  
 Pump orientation: Vertical  
 Shaft seal arrangement: Single  
 Code for shaft seal: HQQE  
 Approvals on nameplate: CE, EAC, ACS  
 Curve tolerance: ISO9906:2012 3B

**Materials:**

Base: Stainless steel  
 EN 1.4408  
 AISI 316  
 Impeller: Stainless steel  
 EN 1.4401  
 AISI 316  
 Bearing: SIC

**Installation:**

Maximum ambient temperature: 60 °C  
 Maximum operating pressure: 25 bar  
 Max pressure at stated temp: 25 bar / 120 °C  
 25 bar / -20 °C  
 Type of connection: PJE  
 Size of inlet connection: DN 32  
 1 1/4 inch  
 Size of outlet connection: DN 32  
 1 1/4 inch  
 Pressure rating for pipe connection: PN 50  
 Flange size for motor: FT100

Qty.	Description
	<p><b>Electrical data:</b></p> <p>Motor standard: IEC</p> <p>Motor type: 80A</p> <p>IE Efficiency class: IE3</p> <p>Rated power - P2: 0.75 kW</p> <p>Power (P2) required by pump: 0.75 kW</p> <p>Mains frequency: 50 Hz</p> <p>Rated voltage: 3 x 220-240D/380-415Y V</p> <p>Rated current: 3.30/1.90 A</p> <p>Starting current: 580-620 %</p> <p>Cos phi - power factor: 0.81-0.71</p> <p>Rated speed: 2840-2870 rpm</p> <p>Efficiency: IE3 80,7%</p> <p>Motor efficiency at full load: 80.7 %</p> <p>Motor efficiency at 3/4 load: 82.7 %</p> <p>Motor efficiency at 1/2 load: 81.7 %</p> <p>Number of poles: 2</p> <p>Enclosure class (IEC 34-5): 55 Dust/Jetting</p> <p>Insulation class (IEC 85): F</p> <p><b>Others:</b></p> <p>Minimum efficiency index, MEI <math>\hat{\alpha}\%</math>: 0.70</p> <p>Net weight: 21.6 kg</p> <p>Gross weight: 24.4 kg</p> <p>Shipping volume: 0.063 m<sup>3</sup></p> <p>Danish VVS No.: 385911008</p> <p>Norwegian NRF no.: 9040465</p> <p>Country of origin: HU</p> <p>Custom tariff no.: 84137075</p>

## 96516901 CRN 3-8 A-P-A-E-HQQE 50 Hz

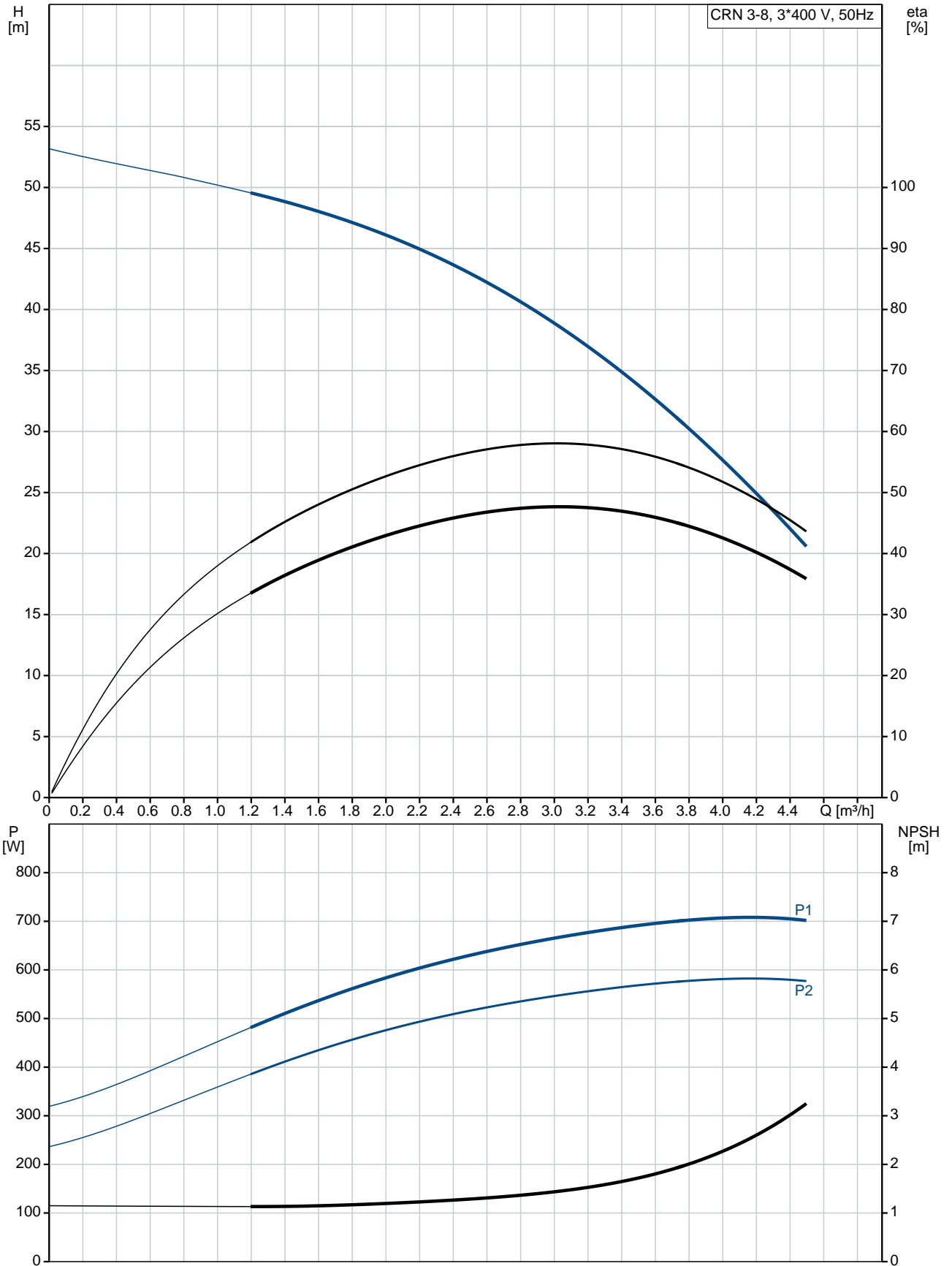

Description	Value
<b>General information:</b>	
Product name:	CRN 3-8 A-P-A-E-HQQE
Product No:	96516901
EAN number:	5700396752136
Price:	931,00 GBP
<b>Technical:</b>	
Pump speed on which pump data are based:	2864 rpm
Rated flow:	3 m <sup>3</sup> /h
Rated head:	38.3 m
Head max:	52.8 m
Stages:	8
Impellers:	8
Number of reduced-diameter impellers:	0
Low NPSH:	N
Pump orientation:	Vertical
Shaft seal arrangement:	Single
Code for shaft seal:	HQQE
Approvals on nameplate:	CE, EAC, ACS
Curve tolerance:	ISO9906:2012 3B
Pump version:	A
Model:	A
<b>Materials:</b>	
Base:	Stainless steel EN 1.4408 AISI 316
Impeller:	Stainless steel EN 1.4401 AISI 316
Material code:	A
Code for rubber:	E
Bearing:	SIC
<b>Installation:</b>	
Maximum ambient temperature:	60 °C
Maximum operating pressure:	25 bar
Max pressure at stated temp:	25 bar / 120 °C 25 bar / -20 °C
Type of connection:	PJE
Size of inlet connection:	DN 32 1 1/4 inch
Size of outlet connection:	DN 32 1 1/4 inch
Pressure rating for pipe connection:	PN 50
Flange size for motor:	FT100
Connect code:	P
<b>Liquid:</b>	
Pumped liquid:	Water
Liquid temperature range:	-20 .. 120 °C
Liquid temperature during operation:	20 °C
Density:	998.2 kg/m <sup>3</sup>
<b>Electrical data:</b>	
Motor standard:	IEC
Motor type:	80A
IE Efficiency class:	IE3
Rated power - P2:	0.75 kW
Power (P2) required by pump:	0.75 kW
Mains frequency:	50 Hz

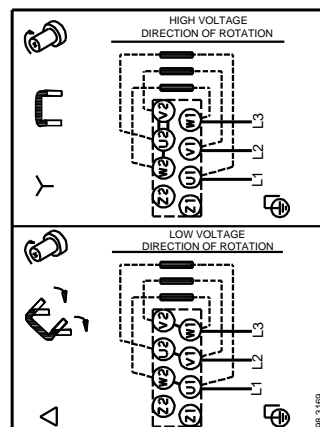
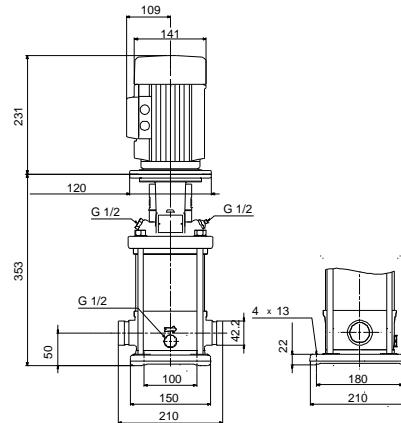
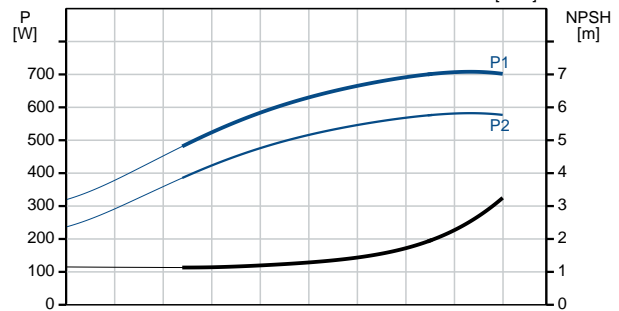
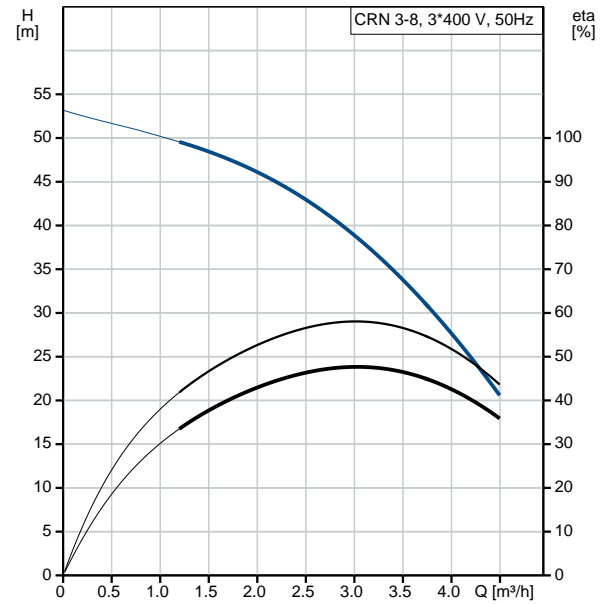

Description	Value
Rated voltage:	3 x 220-240D/380-415Y V
Rated current:	3.30/1.90 A
Starting current:	580-620 %
Cos phi - power factor:	0.81-0.71
Rated speed:	2840-2870 rpm
Efficiency:	IE3 80,7%
Motor efficiency at full load:	80.7 %
Motor efficiency at 3/4 load:	82.7 %
Motor efficiency at 1/2 load:	81.7 %
Number of poles:	2
Enclosure class (IEC 34-5):	55 Dust/Jetting
Insulation class (IEC 85):	F
Motor protec:	NONE
Motor No:	85U05104
<b>Controls:</b>	
Frequency converter:	NONE
<b>Others:</b>	
Minimum efficiency index, MEI $\hat{a}\%$ ¥:	0.70
Net weight:	21.6 kg
Gross weight:	24.4 kg
Shipping volume:	0.063 m <sup>3</sup>
Danish VVS No.:	385911008
Norwegian NRF no.:	9040465
Country of origin:	HU
Custom tariff no.:	84137075

## 96516901 CRN 3-8 A-P-A-E-HQQE 50 Hz

