

| Qty. | Description |
|------|---|
| 1 | <p data-bbox="199 338 496 367">CRN 1-15 A-P-A-E-HQQE</p>  <p data-bbox="199 660 469 689">Product No.: 96516495</p> <p data-bbox="199 719 1453 824">Vertical, multistage centrifugal pump with inlet and outlet ports on same the level (inline). Pump materials in contact with the liquid are in high-grade stainless steel. A cartridge shaft seal ensures high reliability, safe handling, and easy access and service. Power transmission is via a rigid split coupling. Pipe connection is via PJE (Victaulic®) couplings.</p> <p data-bbox="199 862 935 891">The pump is fitted with a 3-phase, fan-cooled asynchronous motor.</p> <p data-bbox="199 920 316 949">Controls:</p> <p data-bbox="199 952 638 981">Frequency converter: NONE</p> <p data-bbox="199 1010 288 1039">Liquid:</p> <p data-bbox="199 1041 707 1160">Pumped liquid: Water Liquid temperature range: -20 .. 120 °C Liquid temperature during operation: 20 °C Density: 998.2 kg/m³</p> <p data-bbox="199 1189 327 1218">Technical:</p> <p data-bbox="199 1220 821 1458">Pump speed on which pump data are based: 2864 rpm Rated flow: 1.8 m³/h Rated head: 69.6 m Pump orientation: Vertical Shaft seal arrangement: Single Code for shaft seal: HQQE Approvals on nameplate: CE, EAC, ACS Curve tolerance: ISO9906:2012 3B</p> <p data-bbox="199 1487 320 1516">Materials:</p> <p data-bbox="199 1518 727 1727">Base: Stainless steel EN 1.4408 AISI 316 Impeller: Stainless steel EN 1.4401 AISI 316 Bearing: SIC</p> <p data-bbox="199 1756 344 1785">Installation:</p> <p data-bbox="199 1787 742 2107">Maximum ambient temperature: 60 °C Maximum operating pressure: 25 bar Max pressure at stated temp: 25 bar / 120 °C 25 bar / -20 °C Type of connection: PJE Size of inlet connection: DN 32 1 1/4 inch Size of outlet connection: DN 32 1 1/4 inch Pressure rating for pipe connection: PN 50 Flange size for motor: FT100</p> |

| Qty. | Description |
|------|--|
| | <p>Electrical data:</p> <p>Motor standard: IEC</p> <p>Motor type: 80A</p> <p>IE Efficiency class: IE3</p> <p>Rated power - P2: 0.75 kW</p> <p>Power (P2) required by pump: 0.75 kW</p> <p>Mains frequency: 50 Hz</p> <p>Rated voltage: 3 x 220-240D/380-415Y V</p> <p>Rated current: 3.30/1.90 A</p> <p>Starting current: 580-620 %</p> <p>Cos phi - power factor: 0.81-0.71</p> <p>Rated speed: 2840-2870 rpm</p> <p>Efficiency: IE3 80,7%</p> <p>Motor efficiency at full load: 80.7 %</p> <p>Motor efficiency at 3/4 load: 82.7 %</p> <p>Motor efficiency at 1/2 load: 81.7 %</p> <p>Number of poles: 2</p> <p>Enclosure class (IEC 34-5): 55 Dust/Jetting</p> <p>Insulation class (IEC 85): F</p> <p>Others:</p> <p>Minimum efficiency index, MEI $\hat{\alpha}\%$: 0.70</p> <p>Net weight: 24.4 kg</p> <p>Gross weight: 27.2 kg</p> <p>Shipping volume: 0.074 m³</p> <p>Danish VVS No.: 385910015</p> <p>Country of origin: GB</p> <p>Custom tariff no.: 84137075</p> |

96516495 CRN 1-15 A-P-A-E-HQQE 50 Hz

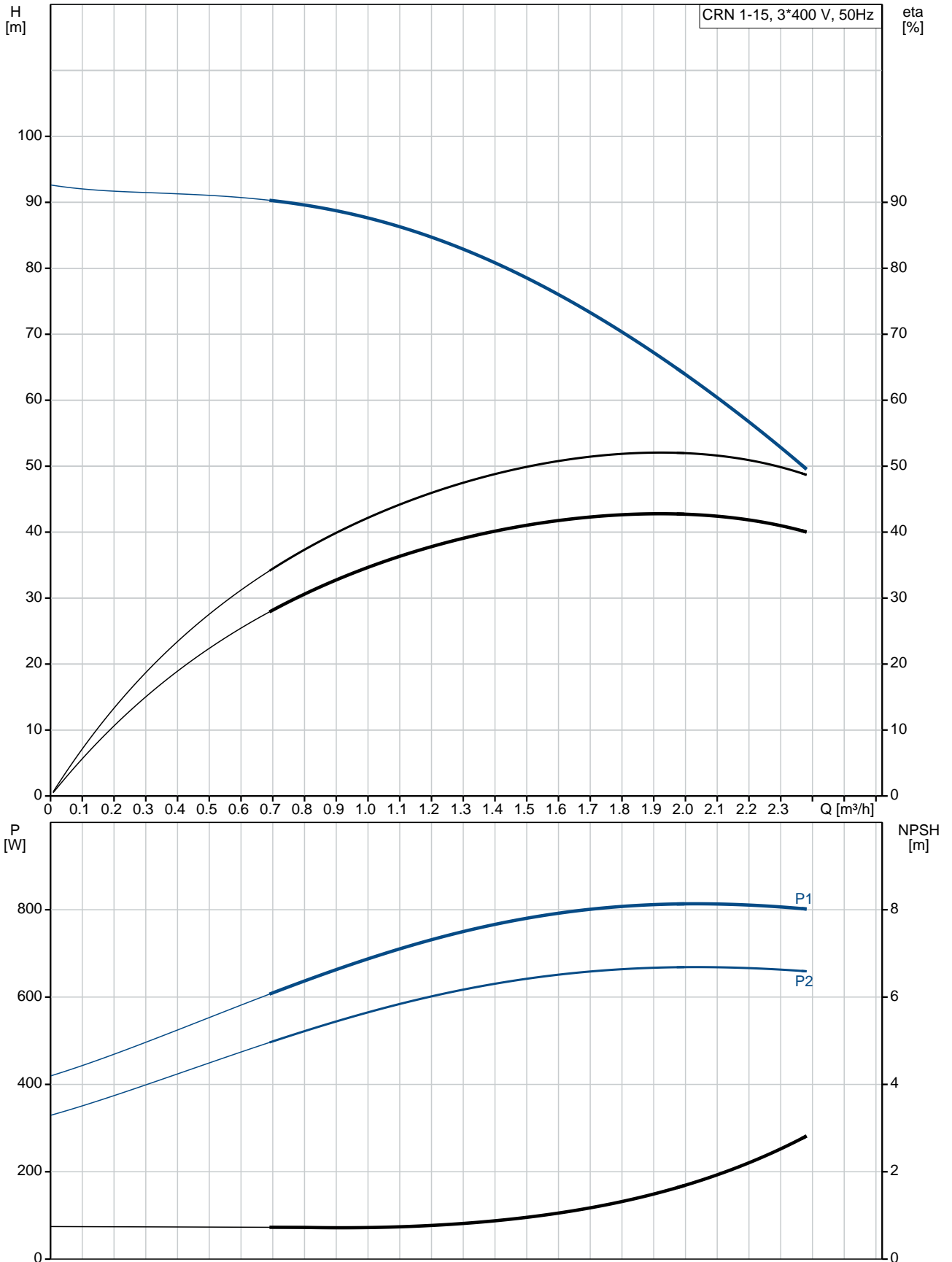

| Description | Value |
|--|--|
| General information: | |
| Product name: | CRN 1-15 A-P-A-E-HQQE |
| Product No: | 96516495 |
| EAN number: | 5700396744322 |
| Price: | 1.109,00 GBP |
| Technical: | |
| Pump speed on which pump data are based: | 2864 rpm |
| Rated flow: | 1.8 m³/h |
| Rated head: | 69.6 m |
| Head max: | 92.6 m |
| Stages: | 15 |
| Impellers: | 15 |
| Number of reduced-diameter impellers: | 0 |
| Low NPSH: | N |
| Pump orientation: | Vertical |
| Shaft seal arrangement: | Single |
| Code for shaft seal: | HQQE |
| Approvals on nameplate: | CE, EAC, ACS |
| Curve tolerance: | ISO9906:2012 3B |
| Pump version: | A |
| Model: | A |
| Materials: | |
| Base: | Stainless steel EN 1.4408 AISI 316 |
| Impeller: | Stainless steel EN 1.4401 AISI 316 |
| Material code: | A |
| Code for rubber: | E |
| Bearing: | SIC |
| Installation: | |
| Maximum ambient temperature: | 60 °C |
| Maximum operating pressure: | 25 bar |
| Max pressure at stated temp: | 25 bar / 120 °C 25 bar / -20 °C |
| Type of connection: | PJE |
| Size of inlet connection: | DN 32 1 1/4 inch |
| Size of outlet connection: | DN 32 1 1/4 inch |
| Pressure rating for pipe connection: | PN 50 |
| Flange size for motor: | FT100 |
| Connect code: | P |
| Liquid: | |
| Pumped liquid: | Water |
| Liquid temperature range: | -20 .. 120 °C |
| Liquid temperature during operation: | 20 °C |
| Density: | 998.2 kg/m³ |
| Electrical data: | |
| Motor standard: | IEC |
| Motor type: | 80A |
| IE Efficiency class: | IE3 |
| Rated power - P2: | 0.75 kW |
| Power (P2) required by pump: | 0.75 kW |
| Mains frequency: | 50 Hz |

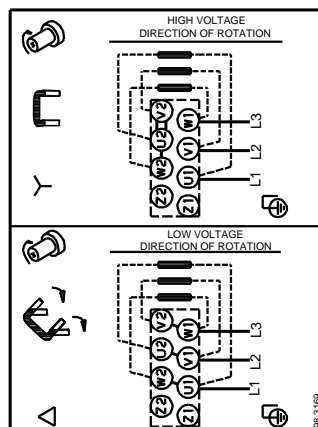
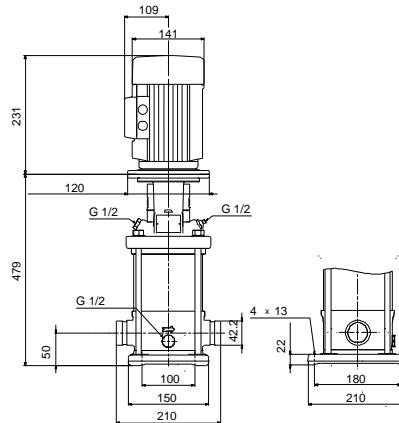
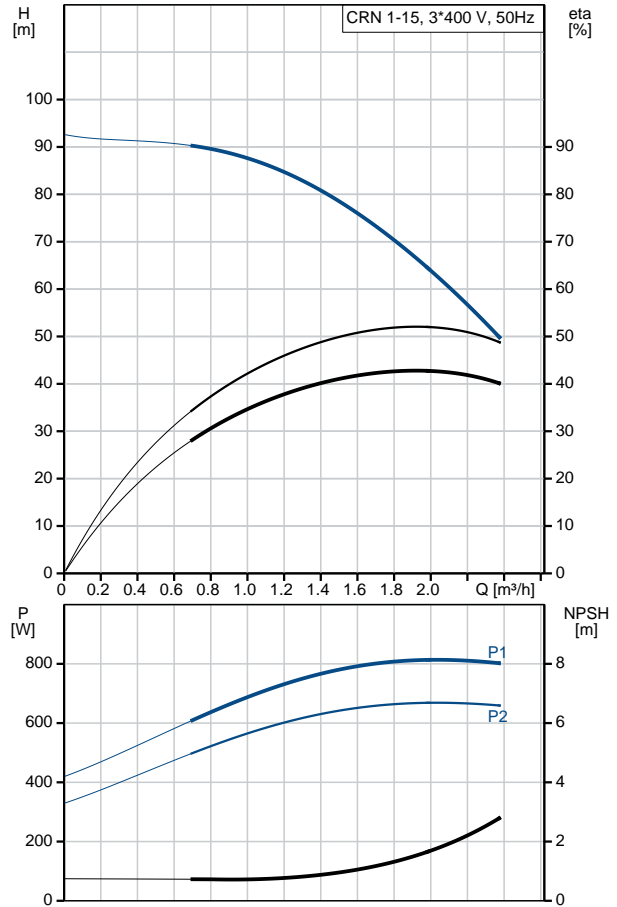



Company name:

Created by:

Phone:

Date:

07/03/2019

| Description | Value |
|----------------------------------|----------------------------|
| Rated voltage: | 3 x 220-240D/380-415Y V |
| Rated current: | 3.30/1.90 A |
| Starting current: | 580-620 % |
| Cos phi - power factor: | 0.81-0.71 |
| Rated speed: | 2840-2870 rpm |
| Efficiency: | IE3 80,7% |
| Motor efficiency at full load: | 80.7 % |
| Motor efficiency at 3/4 load: | 82.7 % |
| Motor efficiency at 1/2 load: | 81.7 % |
| Number of poles: | 2 |
| Enclosure class (IEC 34-5): | 55 Dust/Jetting |
| Insulation class (IEC 85): | F |
| Motor protec: | NONE |
| Motor No: | 85U05104 |
| Controls: | |
| Frequency converter: | NONE |
| Others: | |
| Minimum efficiency index, MEI %: | 0.70 |
| Net weight: | 24.4 kg |
| Gross weight: | 27.2 kg |
| Shipping volume: | 0.074 m ³ |
| Danish VVS No.: | 385910015 |
| Country of origin: | GB |
| Custom tariff no.: | 84137075 |

96516495 CRN 1-15 A-P-A-E-HQQE 50 Hz

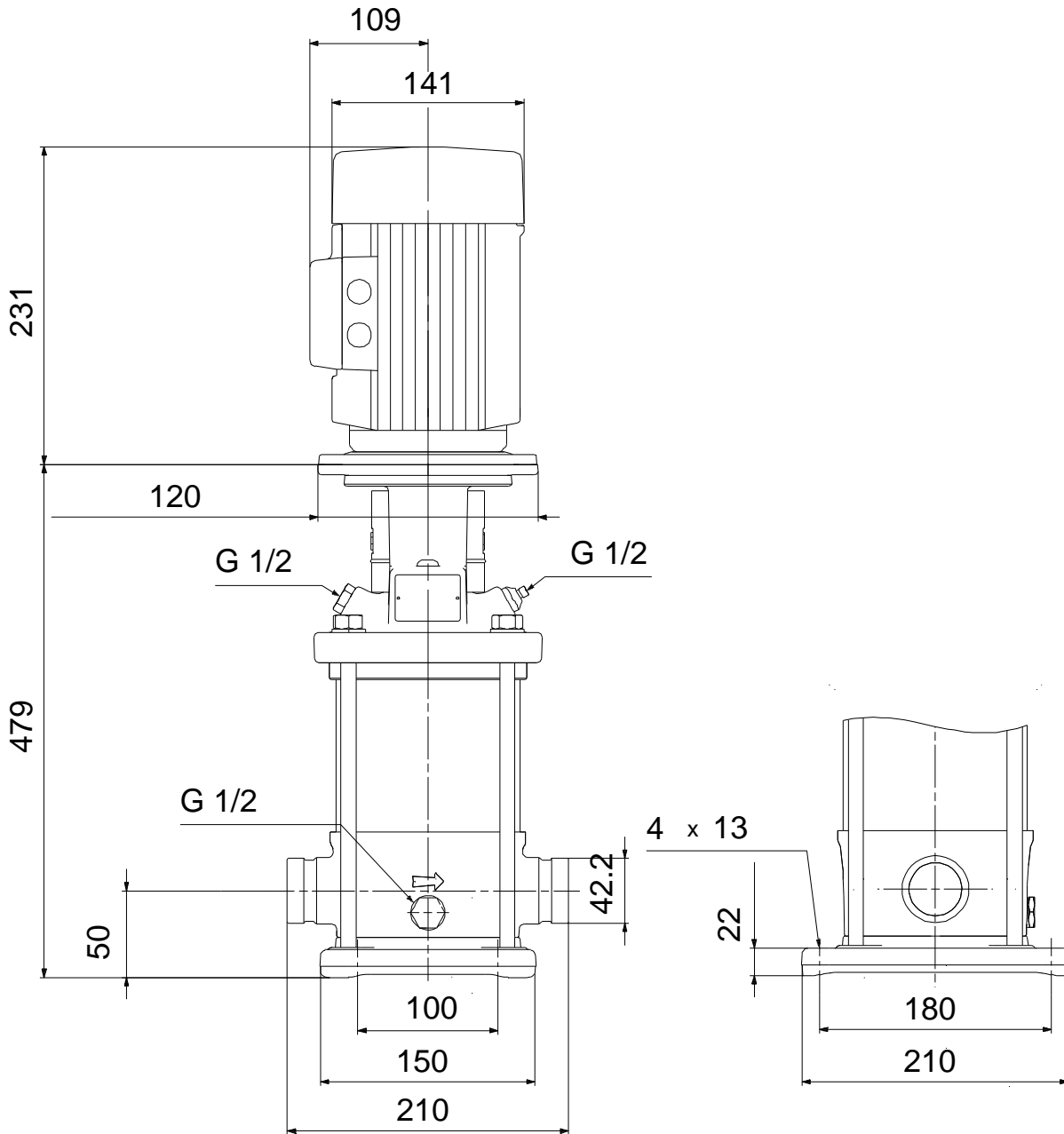

Note! All units are in [mm] unless others are stated.
Disclaimer: This simplified dimensional drawing does not show all details.