

Qty.	Description
1	<p data-bbox="199 340 510 369">CRN 15-12 A-P-A-E-HQQE</p>  <p data-bbox="199 660 470 689">Product No.: 96501956</p> <p data-bbox="199 721 1460 824">Vertical, multistage centrifugal pump with inlet and outlet ports on same the level (inline). Pump materials in contact with the liquid are in high-grade stainless steel. A cartridge shaft seal ensures high reliability, safe handling, and easy access and service. Power transmission is via a rigid split coupling. Pipe connection is via PJE (Victaulic®) couplings.</p> <p data-bbox="199 862 933 891">The pump is fitted with a 3-phase, fan-cooled asynchronous motor.</p> <p data-bbox="199 922 311 952">Controls:</p> <p data-bbox="199 952 638 981">Frequency converter: NONE</p> <p data-bbox="199 1012 287 1041">Liquid:</p> <p data-bbox="199 1041 638 1070">Pumped liquid: Water</p> <p data-bbox="199 1070 710 1099">Liquid temperature range: -20 .. 120 °C</p> <p data-bbox="199 1099 686 1128">Liquid temperature during operation: 20 °C</p> <p data-bbox="199 1128 702 1158">Density: 998.2 kg/m³</p> <p data-bbox="199 1189 327 1218">Technical:</p> <p data-bbox="199 1218 821 1247">Pump speed on which pump data are based: 2924 rpm</p> <p data-bbox="199 1247 654 1276">Rated flow: 17 m³/h</p> <p data-bbox="199 1276 662 1305">Rated head: 135.6 m</p> <p data-bbox="199 1305 654 1335">Pump orientation: Vertical</p> <p data-bbox="199 1335 638 1364">Shaft seal arrangement: Single</p> <p data-bbox="199 1364 638 1393">Code for shaft seal: HQQE</p> <p data-bbox="199 1393 726 1422">Approvals on nameplate: CE, EAC, ACS</p> <p data-bbox="199 1422 766 1451">Curve tolerance: ISO9906:2012 3B</p> <p data-bbox="199 1482 319 1512">Materials:</p> <p data-bbox="199 1512 726 1601">Base: Stainless steel EN 1.4408 AISI 316</p> <p data-bbox="199 1601 726 1691">Impeller: Stainless steel EN 1.4401 AISI 316</p> <p data-bbox="199 1691 614 1720">Bearing: SIC</p> <p data-bbox="199 1751 343 1780">Installation:</p> <p data-bbox="199 1780 630 1809">Maximum ambient temperature: 60 °C</p> <p data-bbox="199 1809 638 1839">Maximum operating pressure: 25 bar</p> <p data-bbox="199 1839 742 1904">Max pressure at stated temp: 25 bar / 120 °C 25 bar / -20 °C</p> <p data-bbox="199 1904 614 1933">Type of connection: PJE</p> <p data-bbox="199 1933 638 1998">Size of inlet connection: DN 50 2 inch</p> <p data-bbox="199 1998 638 2063">Size of outlet connection: DN 50 2 inch</p> <p data-bbox="199 2063 686 2092">Pressure rating for pipe connection: PN 50</p> <p data-bbox="199 2092 638 2121">Flange size for motor: FF300</p>

Qty.	Description
	<p>Electrical data:</p> <p>Motor standard: IEC</p> <p>Motor type: 160MB</p> <p>IE Efficiency class: IE3</p> <p>Rated power - P2: 11 kW</p> <p>Power (P2) required by pump: 11 kW</p> <p>Mains frequency: 50 Hz</p> <p>Rated voltage: 3 x 380-415D/660-690Y V</p> <p>Rated current: 20,8-19,8/12,0-11,8 A</p> <p>Starting current: 660-780 %</p> <p>Cos phi - power factor: 0.88-0.84</p> <p>Rated speed: 2940-2950 rpm</p> <p>Efficiency: IE3 91,2%</p> <p>Motor efficiency at full load: 91.2-91.2 %</p> <p>Motor efficiency at 3/4 load: 91.8 %</p> <p>Motor efficiency at 1/2 load: 91.3 %</p> <p>Number of poles: 2</p> <p>Enclosure class (IEC 34-5): 55 Dust/Jetting</p> <p>Insulation class (IEC 85): F</p> <p>Others:</p> <p>Minimum efficiency index, MEI $\hat{\alpha}\%$: 0.70</p> <p>Net weight: 145 kg</p> <p>Gross weight: 173 kg</p> <p>Shipping volume: 0.488 m³</p> <p>Danish VVS No.: 385914120</p> <p>Country of origin: GB</p> <p>Custom tariff no.: 84137075</p>

96501956 CRN 15-12 A-P-A-E-HQQE 50 Hz

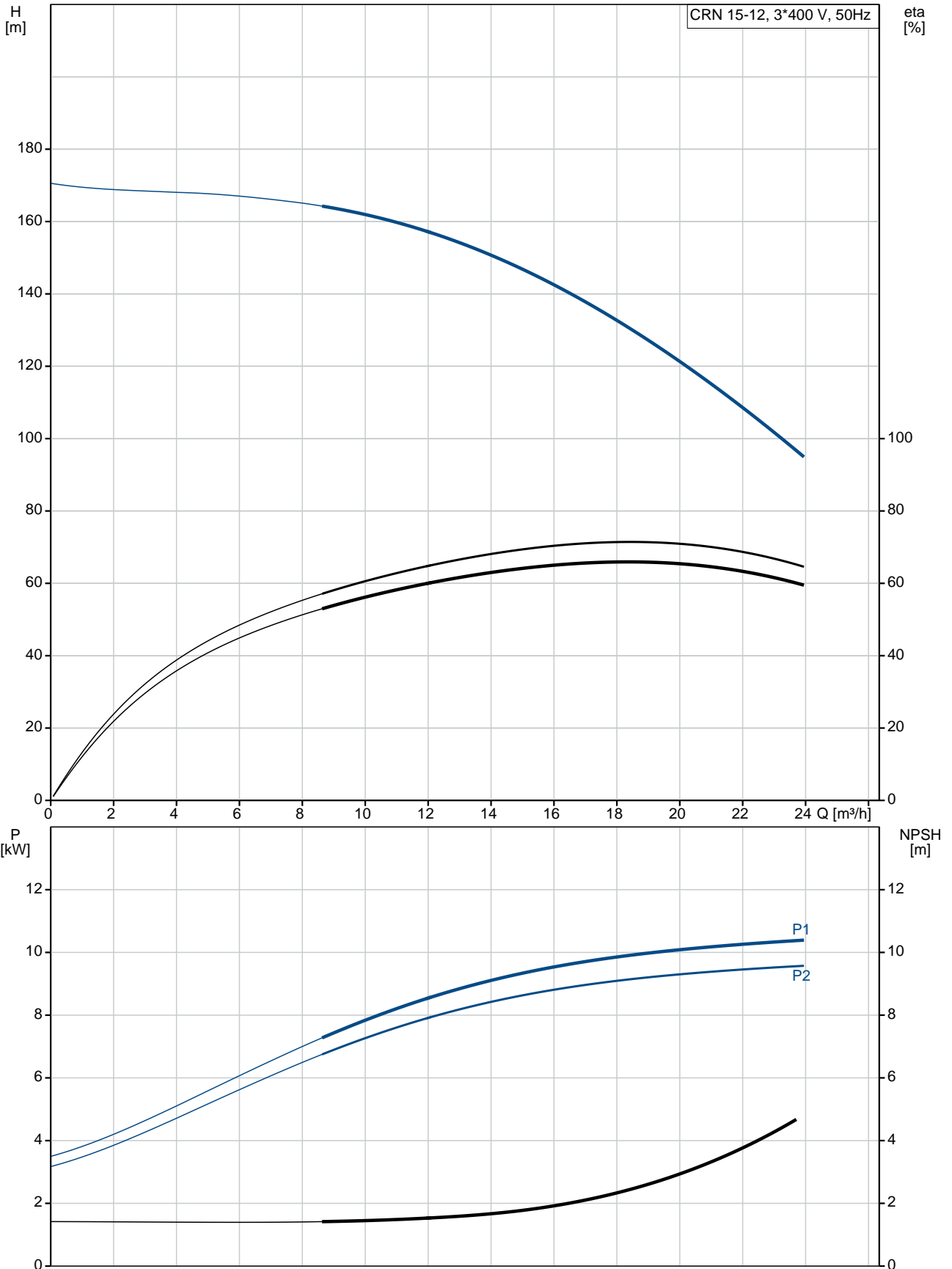

Description	Value
General information:	
Product name:	CRN 15-12 A-P-A-E-HQQE
Product No:	96501956
EAN number:	5700396232584
Price:	4.322,00 GBP
Technical:	
Pump speed on which pump data are based:	2924 rpm
Rated flow:	17 m ³ /h
Rated head:	135.6 m
Head max:	169 m
Stages:	12
Impellers:	12
Number of reduced-diameter impellers:	0
Low NPSH:	N
Pump orientation:	Vertical
Shaft seal arrangement:	Single
Code for shaft seal:	HQQE
Approvals on nameplate:	CE, EAC, ACS
Curve tolerance:	ISO9906:2012 3B
Pump version:	A
Model:	A
Materials:	
Base:	Stainless steel EN 1.4408 AISI 316
Impeller:	Stainless steel EN 1.4401 AISI 316
Material code:	A
Code for rubber:	E
Bearing:	SIC
Installation:	
Maximum ambient temperature:	60 °C
Maximum operating pressure:	25 bar
Max pressure at stated temp:	25 bar / 120 °C 25 bar / -20 °C
Type of connection:	PJE
Size of inlet connection:	DN 50 2 inch
Size of outlet connection:	DN 50 2 inch
Pressure rating for pipe connection:	PN 50
Flange size for motor:	FF300
Connect code:	P
Liquid:	
Pumped liquid:	Water
Liquid temperature range:	-20 .. 120 °C
Liquid temperature during operation:	20 °C
Density:	998.2 kg/m ³
Electrical data:	
Motor standard:	IEC
Motor type:	160MB
IE Efficiency class:	IE3
Rated power - P2:	11 kW
Power (P2) required by pump:	11 kW
Mains frequency:	50 Hz

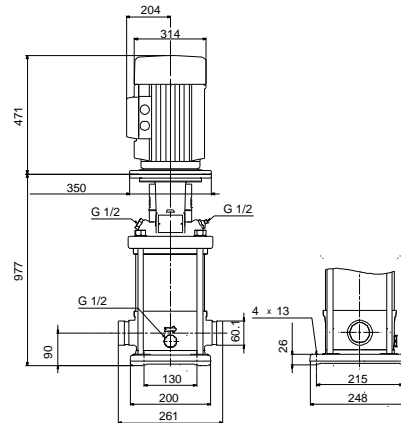
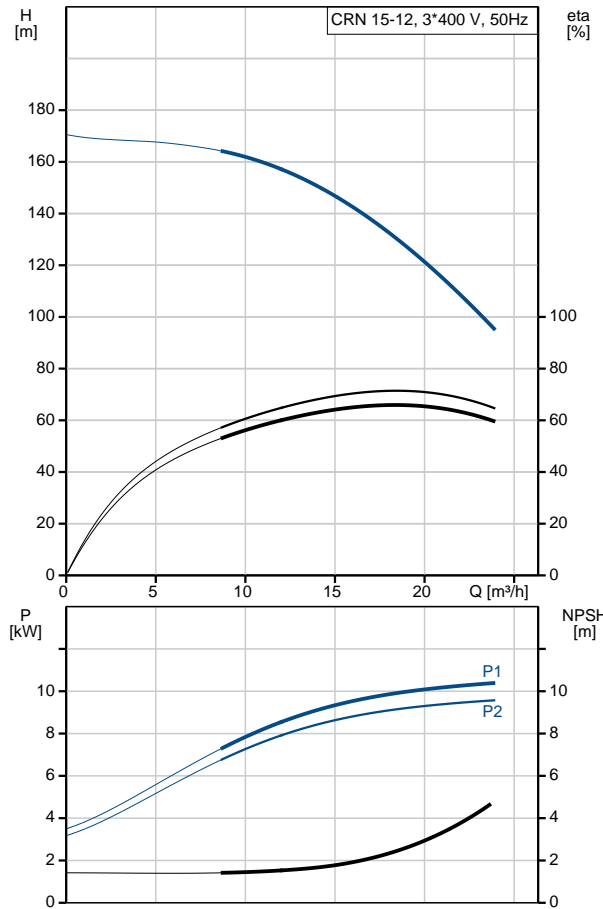



Company name:

Created by:

Phone:

Date:

12/03/2019

Description	Value
Rated voltage:	3 x 380-415D/660-690Y V
Rated current:	20,8-19,8/12,0-11,8 A
Starting current:	660-780 %
Cos phi - power factor:	0.88-0.84
Rated speed:	2940-2950 rpm
Efficiency:	IE3 91,2%
Motor efficiency at full load:	91.2-91.2 %
Motor efficiency at 3/4 load:	91.8 %
Motor efficiency at 1/2 load:	91.3 %
Number of poles:	2
Enclosure class (IEC 34-5):	55 Dust/Jetting
Insulation class (IEC 85):	F
Motor protec:	PTC
Motor No:	85U17524
Controls:	
Frequency converter:	NONE
Others:	
Minimum efficiency index, MEI $\hat{a}\%_{\text{e}}\text{¥}$:	0.70
Net weight:	145 kg
Gross weight:	173 kg
Shipping volume:	0.488 m ³
Danish VVS No.:	385914120
Country of origin:	GB
Custom tariff no.:	84137075

96501956 CRN 15-12 A-P-A-E-HQQE 50 Hz

