

Qty.	Description
------	-------------

1	CRN 15-3 A-P-A-E-HQQE
---	-----------------------



Note! Product picture may differ from actual product

Product No.: [96501758](#)

Vertical, multistage centrifugal pump with inlet and outlet ports on same the level (inline). Pump materials in contact with the liquid are in high-grade stainless steel. A cartridge shaft seal ensures high reliability, safe handling, and easy access and service. Power transmission is via a rigid split coupling. Pipe connection is via PJE (Victaulic®) couplings.

The pump is fitted with a 3-phase, fan-cooled asynchronous motor.

Controls:

Frequency converter: NONE

Liquid:

Pumped liquid: Water
 Liquid temperature range: -20 .. 120 °C
 Liquid temperature during operation: 20 °C
 Density: 998.2 kg/m³

Technical:

Pump speed on which pump data are based: 2902 rpm
 Rated flow: 17 m³/h
 Rated head: 33.2 m
 Pump orientation: Vertical
 Shaft seal arrangement: Single
 Code for shaft seal: HQQE
 Approvals on nameplate: CE, EAC, ACS
 Curve tolerance: ISO9906:2012 3B

Materials:

Base: Stainless steel
 EN 1.4408
 AISI 316
 Impeller: Stainless steel
 EN 1.4401
 AISI 316
 Bearing: SIC

Qty.	Description
	<p>Installation: Maximum ambient temperature: 60 °C Maximum operating pressure: 25 bar Max pressure at stated temp: 25 bar / 120 °C 25 bar / -20 °C Type of connection: PJE Size of inlet connection: DN 50 2 inch Size of outlet connection: DN 50 2 inch Pressure rating for pipe connection: PN 50 Flange size for motor: FT130</p> <p>Electrical data: Motor standard: IEC Motor type: 100LC IE Efficiency class: IE3 Rated power - P2: 3 kW Power (P2) required by pump: 3 kW Mains frequency: 50 Hz Rated voltage: 3 x 220-240D/380-415Y V Rated current: 11.0/6.30 A Starting current: 840-920 % Cos phi - power factor: 0.87-0.82 Rated speed: 2900-2920 rpm Efficiency: IE3 87,1% Motor efficiency at full load: 87.1 % Motor efficiency at 3/4 load: 88.0 % Motor efficiency at 1/2 load: 87.7 % Number of poles: 2 Enclosure class (IEC 34-5): 55 Dust/Jetting Insulation class (IEC 85): F</p> <p>Others: Minimum efficiency index, MEI $\hat{\alpha}\%$: 0.70 Net weight: 52 kg Gross weight: 55 kg Shipping volume: 0.104 m³ Danish VVS No.: 385914030 Country of origin: GB Custom tariff no.: 84137075</p>

96501758 CRN 15-3 A-P-A-E-HQQE 50 Hz

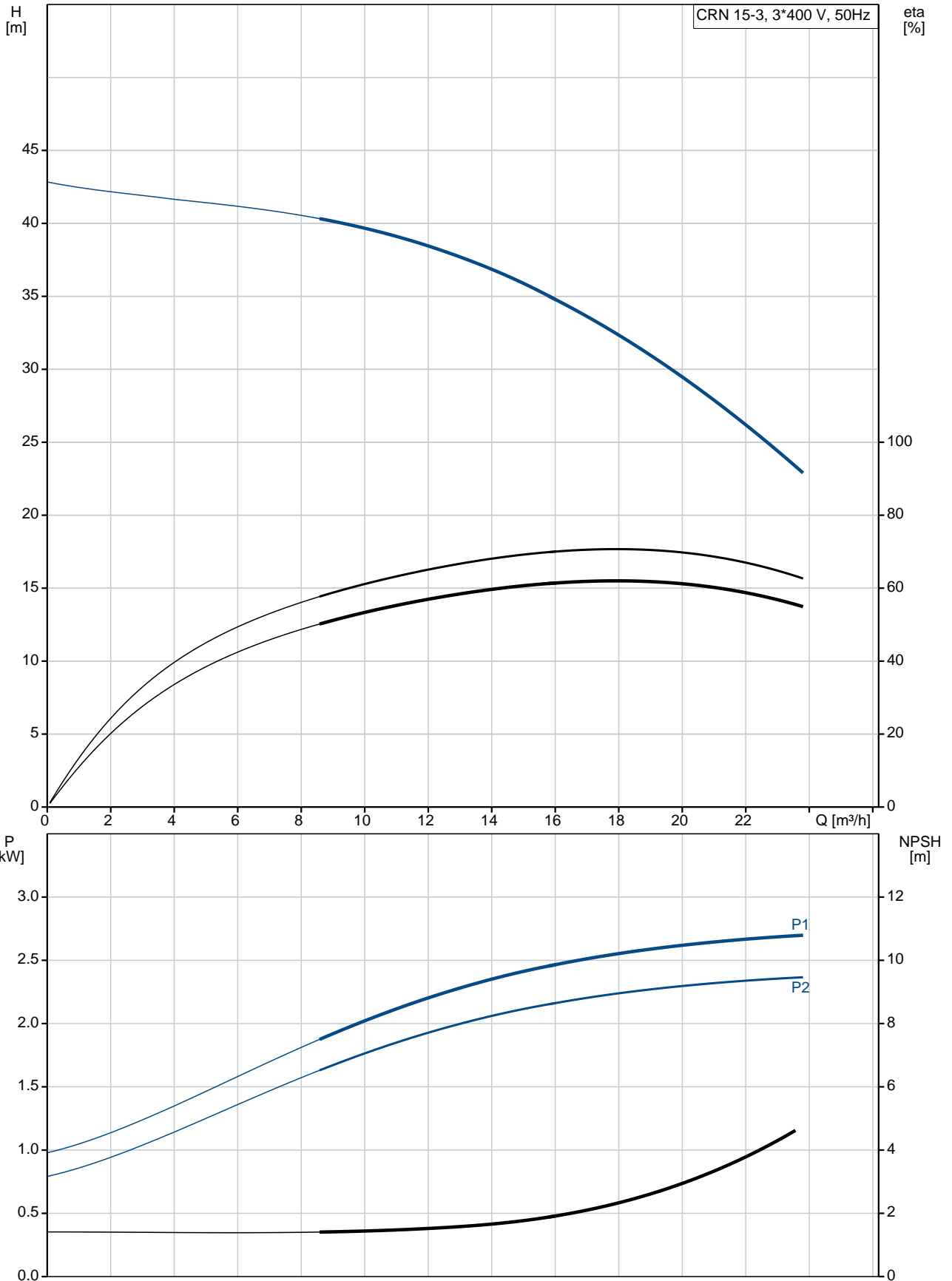

Description	Value
General information:	
Product name:	CRN 15-3 A-P-A-E-HQQE
Product No:	96501758
EAN number:	5700396228624
Price:	1.916,00 GBP
Technical:	
Pump speed on which pump data are based:	2902 rpm
Rated flow:	17 m ³ /h
Rated head:	33.2 m
Head max:	42.7 m
Stages:	3
Impellers:	3
Number of reduced-diameter impellers:	0
Low NPSH:	N
Pump orientation:	Vertical
Shaft seal arrangement:	Single
Code for shaft seal:	HQQE
Approvals on nameplate:	CE, EAC, ACS
Curve tolerance:	ISO9906:2012 3B
Pump version:	A
Model:	A
Materials:	
Base:	Stainless steel EN 1.4408 AISI 316
Impeller:	Stainless steel EN 1.4401 AISI 316
Material code:	A
Code for rubber:	E
Bearing:	SIC
Installation:	
Maximum ambient temperature:	60 °C
Maximum operating pressure:	25 bar
Max pressure at stated temp:	25 bar / 120 °C 25 bar / -20 °C
Type of connection:	PJE
Size of inlet connection:	DN 50 2 inch
Size of outlet connection:	DN 50 2 inch
Pressure rating for pipe connection:	PN 50
Flange size for motor:	FT130
Connect code:	P
Liquid:	
Pumped liquid:	Water
Liquid temperature range:	-20 .. 120 °C
Liquid temperature during operation:	20 °C
Density:	998.2 kg/m ³
Electrical data:	
Motor standard:	IEC
Motor type:	100LC
IE Efficiency class:	IE3
Rated power - P2:	3 kW
Power (P2) required by pump:	3 kW
Mains frequency:	50 Hz

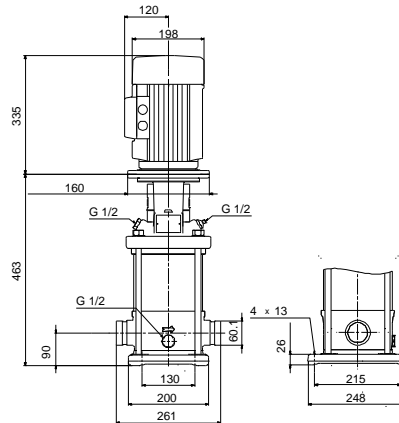
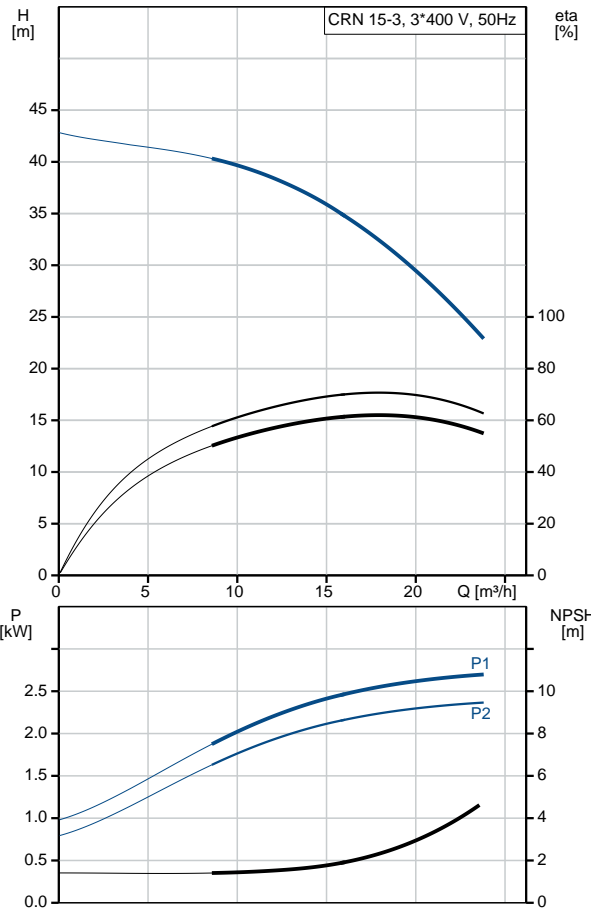



Company name:

Created by:

Phone:

Date:

12/03/2019

Description	Value
Rated voltage:	3 x 220-240D/380-415Y V
Rated current:	11.0/6.30 A
Starting current:	840-920 %
Cos phi - power factor:	0.87-0.82
Rated speed:	2900-2920 rpm
Efficiency:	IE3 87,1%
Motor efficiency at full load:	87.1 %
Motor efficiency at 3/4 load:	88.0 %
Motor efficiency at 1/2 load:	87.7 %
Number of poles:	2
Enclosure class (IEC 34-5):	55 Dust/Jetting
Insulation class (IEC 85):	F
Motor protec:	PTC
Motor No:	85U05510
Controls:	
Frequency converter:	NONE
Others:	
Minimum efficiency index, MEI %:	0.70
Net weight:	52 kg
Gross weight:	55 kg
Shipping volume:	0.104 m ³
Danish VVS No.:	385914030
Country of origin:	GB
Custom tariff no.:	84137075

96501758 CRN 15-3 A-P-A-E-HQQE 50 Hz

