

Qty.	Description
1	<p data-bbox="199 338 496 367">CRN 15-2 A-P-A-E-HQQE</p>  <p data-bbox="199 660 467 689">Product No.: 96501757</p> <p data-bbox="199 719 1453 824">Vertical, multistage centrifugal pump with inlet and outlet ports on same the level (inline). Pump materials in contact with the liquid are in high-grade stainless steel. A cartridge shaft seal ensures high reliability, safe handling, and easy access and service. Power transmission is via a rigid split coupling. Pipe connection is via PJE (Victaulic®) couplings.</p> <p data-bbox="199 862 935 891">The pump is fitted with a 3-phase, fan-cooled asynchronous motor.</p> <p data-bbox="199 922 316 952">Controls:</p> <p data-bbox="199 952 638 981">Frequency converter: NONE</p> <p data-bbox="199 1012 288 1041">Liquid:</p> <p data-bbox="199 1041 707 1160">Pumped liquid: Water Liquid temperature range: -20 .. 120 °C Liquid temperature during operation: 20 °C Density: 998.2 kg/m³</p> <p data-bbox="199 1191 328 1220">Technical:</p> <p data-bbox="199 1220 820 1458">Pump speed on which pump data are based: 2899 rpm Rated flow: 17 m³/h Rated head: 22 m Pump orientation: Vertical Shaft seal arrangement: Single Code for shaft seal: HQQE Approvals on nameplate: CE, EAC, ACS Curve tolerance: ISO9906:2012 3B</p> <p data-bbox="199 1489 320 1518">Materials:</p> <p data-bbox="199 1518 727 1727">Base: Stainless steel EN 1.4408 AISI 316 Impeller: Stainless steel EN 1.4401 AISI 316 Bearing: SIC</p> <p data-bbox="199 1758 344 1787">Installation:</p> <p data-bbox="199 1787 740 2107">Maximum ambient temperature: 60 °C Maximum operating pressure: 25 bar Max pressure at stated temp: 25 bar / 120 °C 25 bar / -20 °C Type of connection: PJE Size of inlet connection: DN 50 2 inch Size of outlet connection: DN 50 2 inch Pressure rating for pipe connection: PN 50 Flange size for motor: FT115</p>

Qty.	Description
------	-------------

Electrical data:

Motor standard:	IEC
Motor type:	90LC
IE Efficiency class:	IE3
Rated power - P2:	2.2 kW
Power (P2) required by pump:	2.2 kW
Mains frequency:	50 Hz
Rated voltage:	3 x 220-240D/380-415Y V
Rated current:	7.70/4.45 A
Starting current:	850-950 %
Cos phi - power factor:	0.89-0.87
Rated speed:	2890-2910 rpm
Efficiency:	IE3 85,9%
Motor efficiency at full load:	85.9 %
Motor efficiency at 3/4 load:	86.8 %
Motor efficiency at 1/2 load:	86.0 %
Number of poles:	2
Enclosure class (IEC 34-5):	55 Dust/Jetting
Insulation class (IEC 85):	F

Others:

Minimum efficiency index, MEI $\hat{\alpha}\%$:	0.70
Net weight:	46 kg
Gross weight:	50 kg
Shipping volume:	0.094 m ³
Danish VVS No.:	385914020
Country of origin:	GB
Custom tariff no.:	84137075

96501757 CRN 15-2 A-P-A-E-HQQE 50 Hz

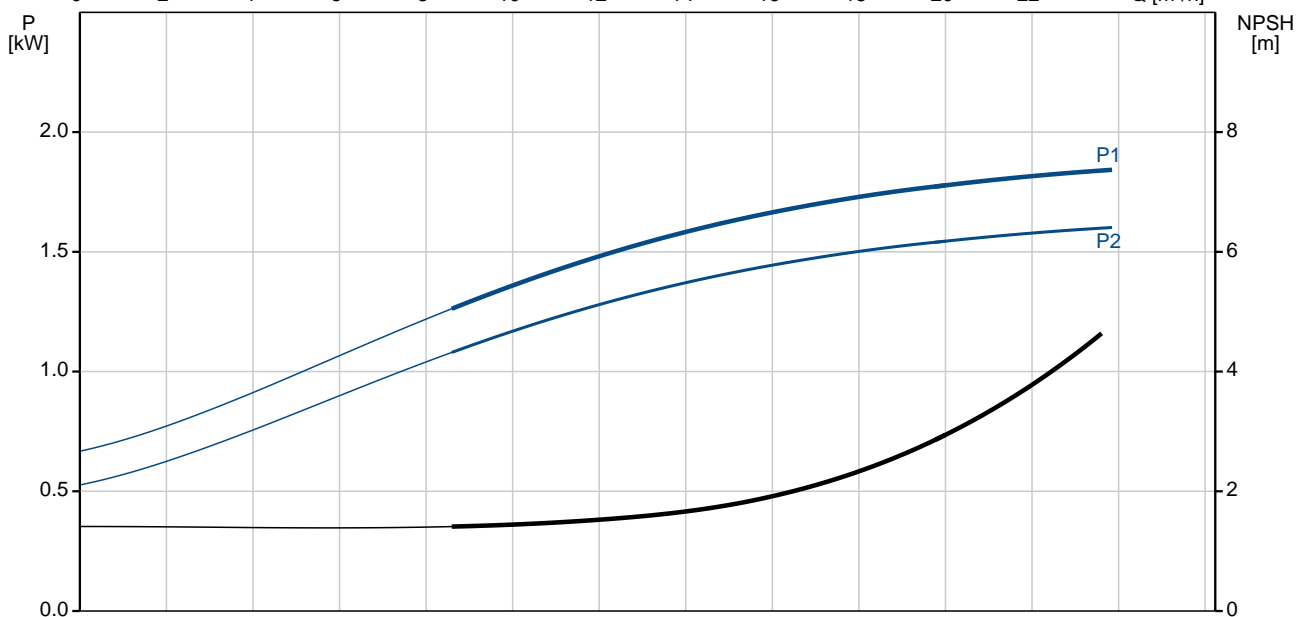
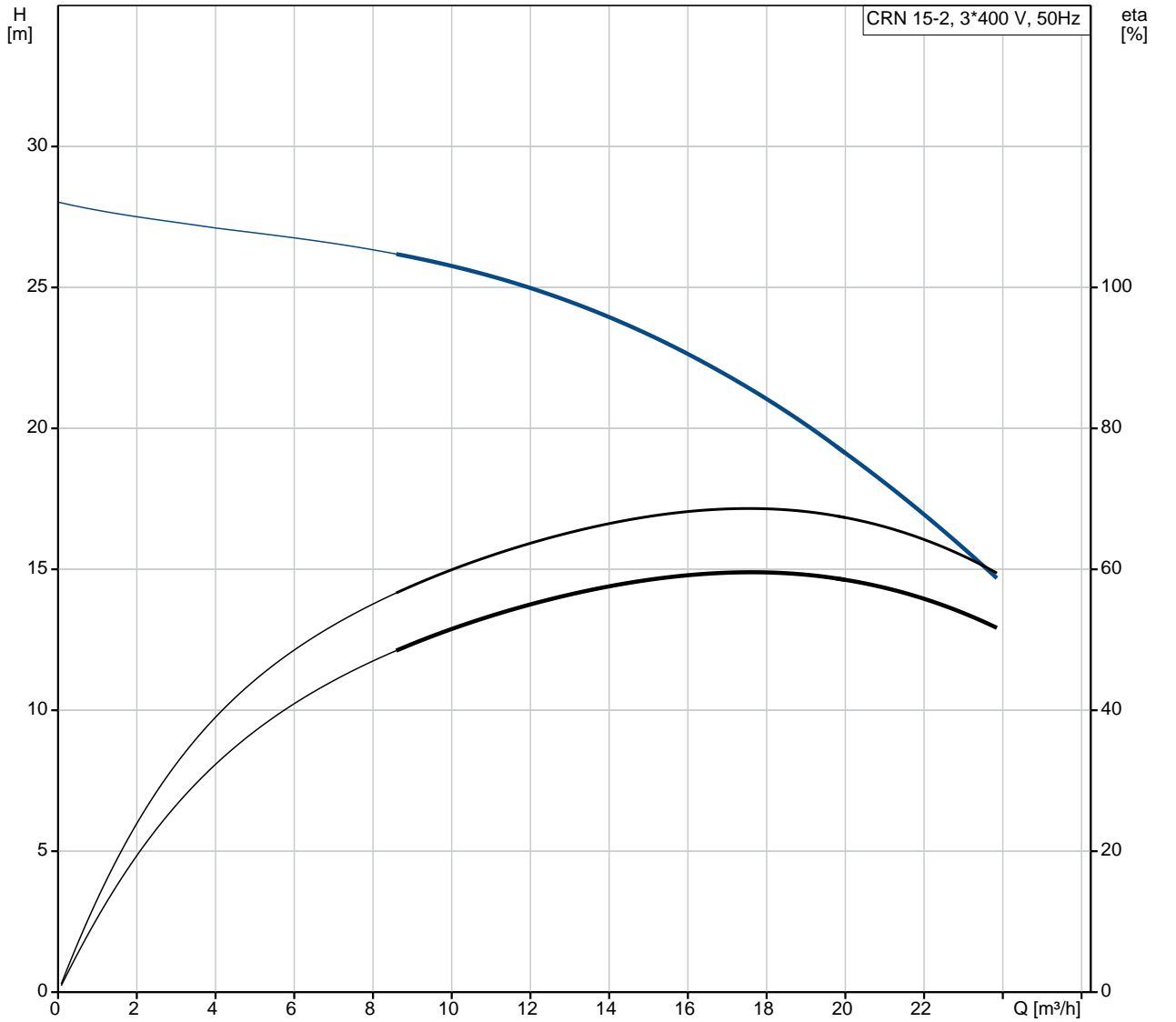

Description	Value
General information:	
Product name:	CRN 15-2 A-P-A-E-HQQE
Product No:	96501757
EAN number:	5700396228600
Price:	1.671,00 GBP
Technical:	
Pump speed on which pump data are based:	2899 rpm
Rated flow:	17 m ³ /h
Rated head:	22 m
Head max:	28.7 m
Stages:	2
Impellers:	2
Number of reduced-diameter impellers:	0
Low NPSH:	N
Pump orientation:	Vertical
Shaft seal arrangement:	Single
Code for shaft seal:	HQQE
Approvals on nameplate:	CE, EAC, ACS
Curve tolerance:	ISO9906:2012 3B
Pump version:	A
Model:	A
Materials:	
Base:	Stainless steel EN 1.4408 AISI 316
Impeller:	Stainless steel EN 1.4401 AISI 316
Material code:	A
Code for rubber:	E
Bearing:	SIC
Installation:	
Maximum ambient temperature:	60 °C
Maximum operating pressure:	25 bar
Max pressure at stated temp:	25 bar / 120 °C 25 bar / -20 °C
Type of connection:	PJE
Size of inlet connection:	DN 50 2 inch
Size of outlet connection:	DN 50 2 inch
Pressure rating for pipe connection:	PN 50
Flange size for motor:	FT115
Connect code:	P
Liquid:	
Pumped liquid:	Water
Liquid temperature range:	-20 .. 120 °C
Liquid temperature during operation:	20 °C
Density:	998.2 kg/m ³
Electrical data:	
Motor standard:	IEC
Motor type:	90LC
IE Efficiency class:	IE3
Rated power - P2:	2.2 kW
Power (P2) required by pump:	2.2 kW
Mains frequency:	50 Hz

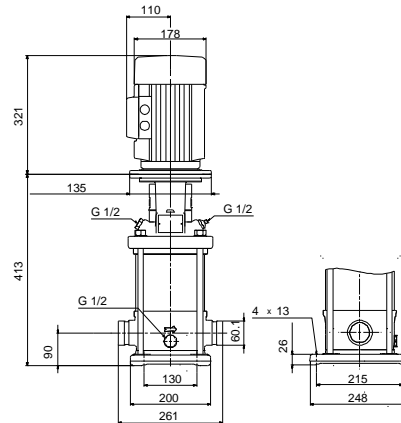
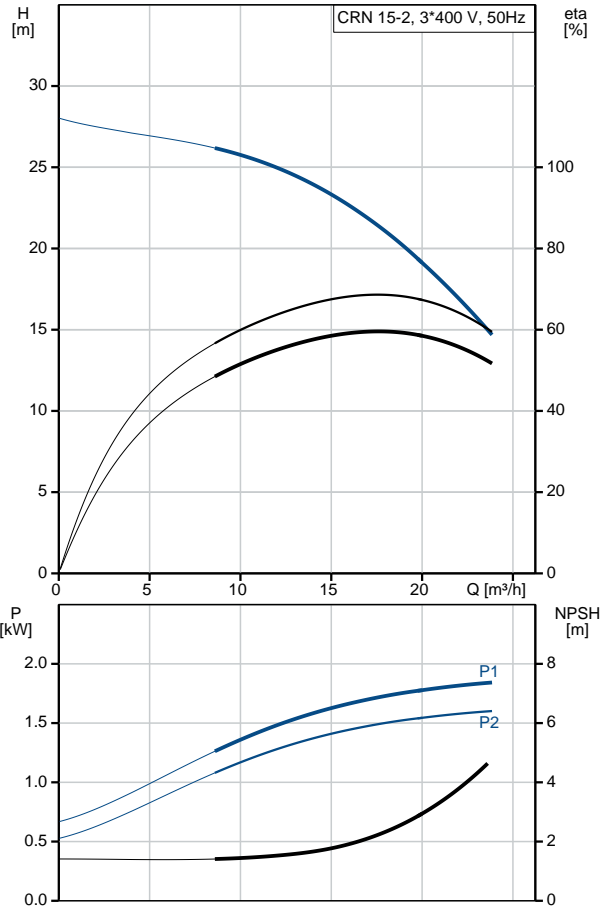



Company name:

Created by:

Phone:

Date:

12/03/2019

Description	Value
Rated voltage:	3 x 220-240D/380-415Y V
Rated current:	7.70/4.45 A
Starting current:	850-950 %
Cos phi - power factor:	0.89-0.87
Rated speed:	2890-2910 rpm
Efficiency:	IE3 85,9%
Motor efficiency at full load:	85.9 %
Motor efficiency at 3/4 load:	86.8 %
Motor efficiency at 1/2 load:	86.0 %
Number of poles:	2
Enclosure class (IEC 34-5):	55 Dust/Jetting
Insulation class (IEC 85):	F
Motor protec:	NONE
Motor No:	85U05908
Controls:	
Frequency converter:	NONE
Others:	
Minimum efficiency index, MEI %:	0.70
Net weight:	46 kg
Gross weight:	50 kg
Shipping volume:	0.094 m ³
Danish VVS No.:	385914020
Country of origin:	GB
Custom tariff no.:	84137075

96501757 CRN 15-2 A-P-A-E-HQQE 50 Hz

