

Qty.	Description
1	<p data-bbox="199 336 510 369">CRN 20-12 A-P-A-E-HQQE</p>  <p data-bbox="199 660 470 683">Product No.: 96500566</p> <p data-bbox="199 716 1460 817">Vertical, multistage centrifugal pump with inlet and outlet ports on same the level (inline). Pump materials in contact with the liquid are in high-grade stainless steel. A cartridge shaft seal ensures high reliability, safe handling, and easy access and service. Power transmission is via a rigid split coupling. Pipe connection is via PJE (Victaulic®) couplings.</p> <p data-bbox="199 862 933 884">The pump is fitted with a 3-phase, fan-cooled asynchronous motor.</p> <p data-bbox="199 918 319 940">Controls:</p> <p data-bbox="199 952 638 974">Frequency converter: NONE</p> <p data-bbox="199 1008 287 1030">Liquid:</p> <p data-bbox="199 1041 638 1064">Pumped liquid: Water</p> <p data-bbox="199 1070 710 1093">Liquid temperature range: -20 .. 120 °C</p> <p data-bbox="199 1099 686 1122">Liquid temperature during operation: 20 °C</p> <p data-bbox="199 1128 702 1151">Density: 998.2 kg/m³</p> <p data-bbox="199 1187 327 1209">Technical:</p> <p data-bbox="199 1220 821 1243">Pump speed on which pump data are based: 2923 rpm</p> <p data-bbox="199 1249 654 1272">Rated flow: 21 m³/h</p> <p data-bbox="199 1279 662 1301">Rated head: 142.7 m</p> <p data-bbox="199 1308 654 1330">Pump orientation: Vertical</p> <p data-bbox="199 1337 638 1359">Shaft seal arrangement: Single</p> <p data-bbox="199 1366 638 1388">Code for shaft seal: HQQE</p> <p data-bbox="199 1395 726 1417">Approvals on nameplate: CE, EAC, ACS</p> <p data-bbox="199 1424 766 1447">Curve tolerance: ISO9906:2012 3B</p> <p data-bbox="199 1482 319 1505">Materials:</p> <p data-bbox="199 1516 726 1601">Base: Stainless steel EN 1.4408 AISI 316</p> <p data-bbox="199 1608 726 1693">Impeller: Stainless steel EN 1.4401 AISI 316</p> <p data-bbox="199 1700 606 1722">Bearing: SIC</p> <p data-bbox="199 1758 343 1780">Installation:</p> <p data-bbox="199 1787 630 1809">Maximum ambient temperature: 60 °C</p> <p data-bbox="199 1816 638 1839">Maximum operating pressure: 25 bar</p> <p data-bbox="199 1845 742 1899">Max pressure at stated temp: 25 bar / 120 °C 25 bar / -20 °C</p> <p data-bbox="199 1906 614 1928">Type of connection: PJE</p> <p data-bbox="199 1935 638 1989">Size of inlet connection: DN 50 2 inch</p> <p data-bbox="199 1995 638 2049">Size of outlet connection: DN 50 2 inch</p> <p data-bbox="199 2056 686 2078">Pressure rating for pipe connection: PN 50</p> <p data-bbox="199 2085 638 2107">Flange size for motor: FF300</p>

Qty.	Description
------	-------------

Electrical data:

Motor standard:	IEC
Motor type:	160MD
IE Efficiency class:	IE3
Rated power - P2:	15 kW
Power (P2) required by pump:	15 kW
Mains frequency:	50 Hz
Rated voltage:	3 x 380-415D/660-690Y V
Rated current:	28,0-26,0/16,2-15,6 A
Starting current:	660-780 %
Cos phi - power factor:	0.89-0.87
Rated speed:	2930-2950 rpm
Efficiency:	IE3 91,9%
Motor efficiency at full load:	91.9-91.9 %
Motor efficiency at 3/4 load:	92.4 %
Motor efficiency at 1/2 load:	92.4 %
Number of poles:	2
Enclosure class (IEC 34-5):	55 Dust/Jetting
Insulation class (IEC 85):	F

Others:

Minimum efficiency index, MEI $\hat{\alpha}\%$:	0.70
Net weight:	157 kg
Gross weight:	185 kg
Shipping volume:	0.488 m ³
Danish VVS No.:	385915120
Country of origin:	GB
Custom tariff no.:	84137075

96500566 CRN 20-12 A-P-A-E-HQQE 50 Hz

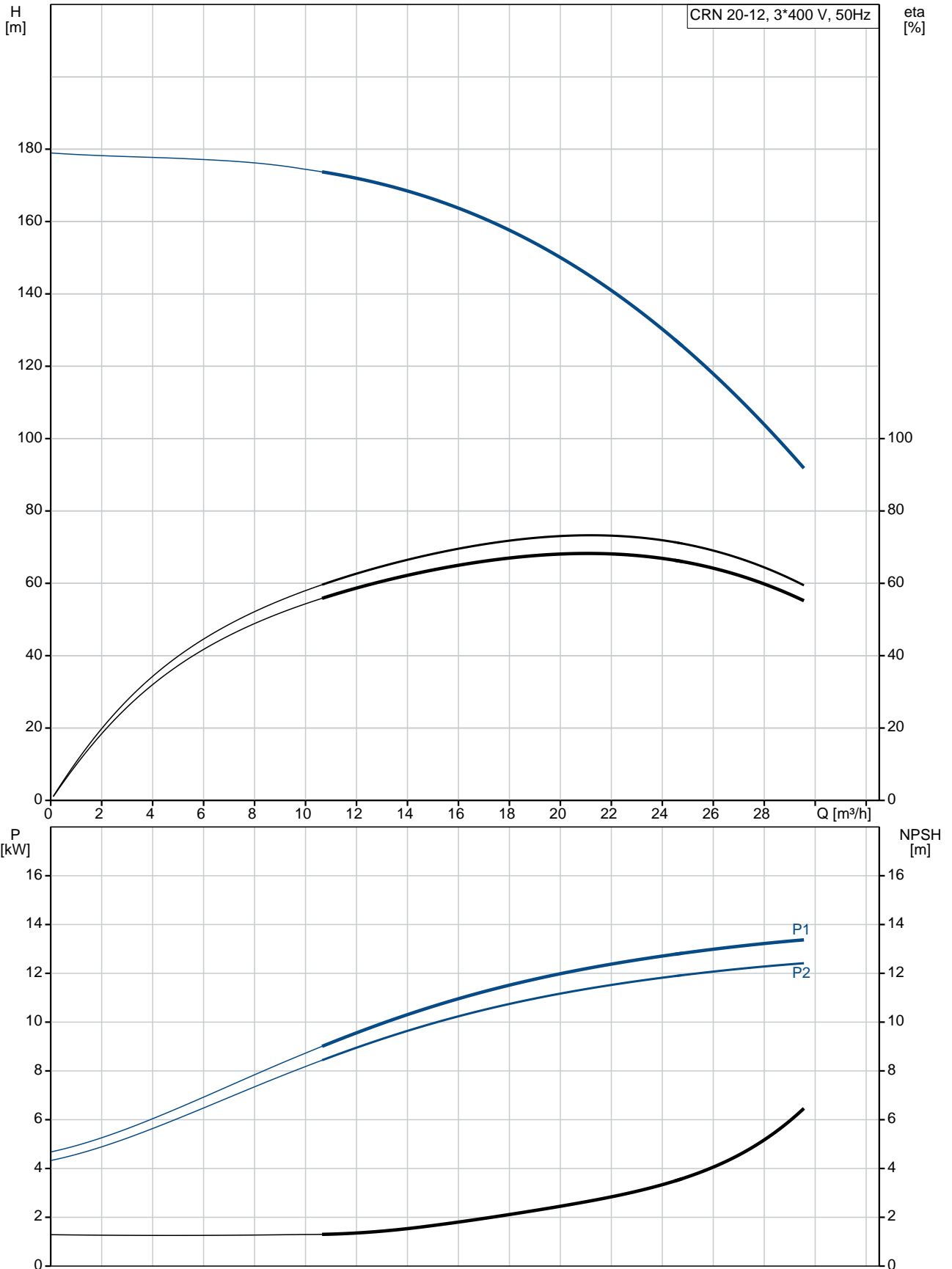

Description	Value
General information:	
Product name:	CRN 20-12 A-P-A-E-HQQE
Product No:	96500566
EAN number:	5700396204383
Price:	5.714,00 GBP
Technical:	
Pump speed on which pump data are based:	2923 rpm
Rated flow:	21 m ³ /h
Rated head:	142.7 m
Head max:	178 m
Stages:	12
Impellers:	12
Number of reduced-diameter impellers:	0
Low NPSH:	N
Pump orientation:	Vertical
Shaft seal arrangement:	Single
Code for shaft seal:	HQQE
Approvals on nameplate:	CE, EAC, ACS
Curve tolerance:	ISO9906:2012 3B
Pump version:	A
Model:	A
Materials:	
Base:	Stainless steel EN 1.4408 AISI 316
Impeller:	Stainless steel EN 1.4401 AISI 316
Material code:	A
Code for rubber:	E
Bearing:	SIC
Installation:	
Maximum ambient temperature:	60 °C
Maximum operating pressure:	25 bar
Max pressure at stated temp:	25 bar / 120 °C 25 bar / -20 °C
Type of connection:	PJE
Size of inlet connection:	DN 50 2 inch
Size of outlet connection:	DN 50 2 inch
Pressure rating for pipe connection:	PN 50
Flange size for motor:	FF300
Connect code:	P
Liquid:	
Pumped liquid:	Water
Liquid temperature range:	-20 .. 120 °C
Liquid temperature during operation:	20 °C
Density:	998.2 kg/m ³
Electrical data:	
Motor standard:	IEC
Motor type:	160MD
IE Efficiency class:	IE3
Rated power - P2:	15 kW
Power (P2) required by pump:	15 kW
Mains frequency:	50 Hz

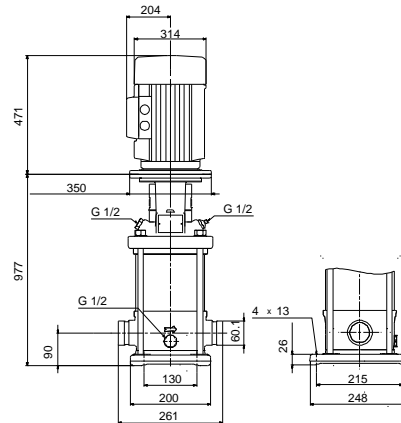
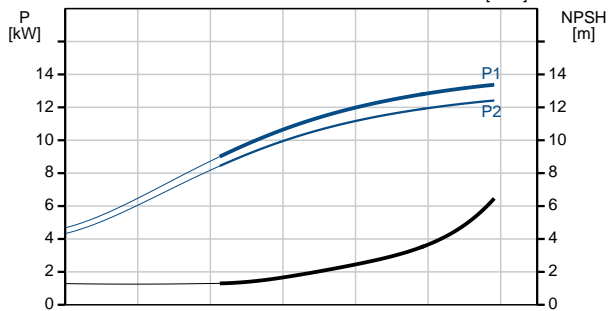
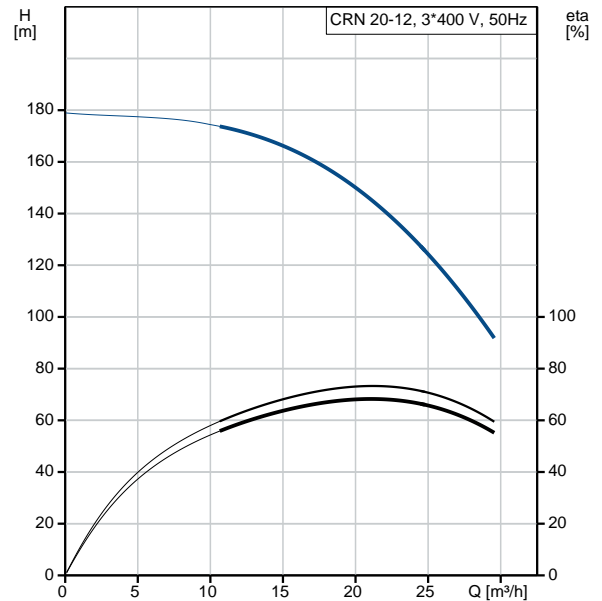



Company name:

Created by:

Phone:

Date:

12/03/2019

Description	Value
Rated voltage:	3 x 380-415D/660-690Y V
Rated current:	28,0-26,0/16,2-15,6 A
Starting current:	660-780 %
Cos phi - power factor:	0.89-0.87
Rated speed:	2930-2950 rpm
Efficiency:	IE3 91,9%
Motor efficiency at full load:	91.9-91.9 %
Motor efficiency at 3/4 load:	92.4 %
Motor efficiency at 1/2 load:	92.4 %
Number of poles:	2
Enclosure class (IEC 34-5):	55 Dust/Jetting
Insulation class (IEC 85):	F
Motor protec:	PTC
Motor No:	85U17526
Controls:	
Frequency converter:	NONE
Others:	
Minimum efficiency index, MEI $\hat{a}\%$ ¥:	0.70
Net weight:	157 kg
Gross weight:	185 kg
Shipping volume:	0.488 m ³
Danish VVS No.:	385915120
Country of origin:	GB
Custom tariff no.:	84137075

96500566 CRN 20-12 A-P-A-E-HQQE 50 Hz

