

Qty.	Description																																																		
1	<p data-bbox="199 340 486 362">SEV.100.100.75.A.4.51D</p> <div data-bbox="226 385 561 660">  </div> <p data-bbox="593 645 1077 667">Note! Product picture may differ from actual product</p> <p data-bbox="199 676 470 698">Product No.: 96177672</p> <p data-bbox="199 734 1460 788">Non-self-priming, single-stage, centrifugal pump designed for handling wastewater, process water and unscreened raw sewage.</p> <p data-bbox="199 795 1460 896">The pump is designed for intermittent and continuous operation. The liquidless and maintenance free cooling system ensures that the pump can be used for submerged or dry installation. The efficient SuperVortex impeller provides passage of long fibres and solids up to 100 mm and is suitable for wastewater with a dry matter content of up to 5 %.</p> <p data-bbox="199 907 1460 963">A unique stainless-steel clamp assembling system enables quick and easy disassembly of the pump from the motor unit for service and inspection. No special tools are required. Pipework connection is via a DIN flange.</p> <p data-bbox="199 1025 311 1048">Controls:</p> <table data-bbox="199 1052 821 1137"> <tr> <td>Moisture sensor:</td> <td>with moisture sensors</td> </tr> <tr> <td>Water-in-oil sensor:</td> <td>with water-in-oil sensor</td> </tr> <tr> <td>Temp. sensor:</td> <td>Y</td> </tr> </table> <p data-bbox="199 1176 287 1198">Liquid:</p> <table data-bbox="199 1205 798 1290"> <tr> <td>Pumped liquid:</td> <td>Any Newtonian liquid</td> </tr> <tr> <td>Liquid temperature range:</td> <td>0 .. 40 °C</td> </tr> <tr> <td>Density:</td> <td>998.2 kg/m³</td> </tr> </table> <p data-bbox="199 1326 327 1348">Technical:</p> <table data-bbox="199 1355 813 1556"> <tr> <td>Type of impeller:</td> <td>SUPER VORTEX</td> </tr> <tr> <td>Maximum particle size:</td> <td>100 mm</td> </tr> <tr> <td>Primary shaft seal:</td> <td>SIC/SIC</td> </tr> <tr> <td>Secondary shaft seal:</td> <td>CARBON/CERAMICS</td> </tr> <tr> <td>Max. hydraulic efficiency:</td> <td>48 %</td> </tr> <tr> <td>Approvals on nameplate:</td> <td>EN12050-1</td> </tr> <tr> <td>Curve tolerance:</td> <td>ISO9906:2012 3B2</td> </tr> </table> <p data-bbox="199 1594 319 1617">Materials:</p> <table data-bbox="199 1624 805 1675"> <tr> <td>Pump housing:</td> <td>EN 1561 EN-GJL-250</td> </tr> <tr> <td>Impeller:</td> <td>Cast iron</td> </tr> </table> <p data-bbox="199 1713 343 1736">Installation:</p> <table data-bbox="199 1742 654 1915"> <tr> <td>Maximum ambient temperature:</td> <td>40 °C</td> </tr> <tr> <td>Maximum operating pressure:</td> <td>6 bar</td> </tr> <tr> <td>Flange standard:</td> <td>DIN</td> </tr> <tr> <td>Pump outlet:</td> <td>DN 100</td> </tr> <tr> <td>Pressure rating:</td> <td>PN 10</td> </tr> <tr> <td>Maximum installation depth:</td> <td>20 m</td> </tr> </table> <p data-bbox="199 1953 375 1975">Electrical data:</p> <table data-bbox="199 1982 726 2094"> <tr> <td>Power input - P1:</td> <td>9 kW</td> </tr> <tr> <td>Rated power - P2:</td> <td>7.5 kW</td> </tr> <tr> <td>Mains frequency:</td> <td>50 Hz</td> </tr> <tr> <td>Rated voltage:</td> <td>3 x 380-415 V</td> </tr> </table>	Moisture sensor:	with moisture sensors	Water-in-oil sensor:	with water-in-oil sensor	Temp. sensor:	Y	Pumped liquid:	Any Newtonian liquid	Liquid temperature range:	0 .. 40 °C	Density:	998.2 kg/m ³	Type of impeller:	SUPER VORTEX	Maximum particle size:	100 mm	Primary shaft seal:	SIC/SIC	Secondary shaft seal:	CARBON/CERAMICS	Max. hydraulic efficiency:	48 %	Approvals on nameplate:	EN12050-1	Curve tolerance:	ISO9906:2012 3B2	Pump housing:	EN 1561 EN-GJL-250	Impeller:	Cast iron	Maximum ambient temperature:	40 °C	Maximum operating pressure:	6 bar	Flange standard:	DIN	Pump outlet:	DN 100	Pressure rating:	PN 10	Maximum installation depth:	20 m	Power input - P1:	9 kW	Rated power - P2:	7.5 kW	Mains frequency:	50 Hz	Rated voltage:	3 x 380-415 V
Moisture sensor:	with moisture sensors																																																		
Water-in-oil sensor:	with water-in-oil sensor																																																		
Temp. sensor:	Y																																																		
Pumped liquid:	Any Newtonian liquid																																																		
Liquid temperature range:	0 .. 40 °C																																																		
Density:	998.2 kg/m ³																																																		
Type of impeller:	SUPER VORTEX																																																		
Maximum particle size:	100 mm																																																		
Primary shaft seal:	SIC/SIC																																																		
Secondary shaft seal:	CARBON/CERAMICS																																																		
Max. hydraulic efficiency:	48 %																																																		
Approvals on nameplate:	EN12050-1																																																		
Curve tolerance:	ISO9906:2012 3B2																																																		
Pump housing:	EN 1561 EN-GJL-250																																																		
Impeller:	Cast iron																																																		
Maximum ambient temperature:	40 °C																																																		
Maximum operating pressure:	6 bar																																																		
Flange standard:	DIN																																																		
Pump outlet:	DN 100																																																		
Pressure rating:	PN 10																																																		
Maximum installation depth:	20 m																																																		
Power input - P1:	9 kW																																																		
Rated power - P2:	7.5 kW																																																		
Mains frequency:	50 Hz																																																		
Rated voltage:	3 x 380-415 V																																																		

Qty.	Description
	<p>Voltage tolerance: +6/-10 %</p> <p>Max starts per. hour: 20</p> <p>Rated current: 17.7-17.5 A</p> <p>Rated current at 3/4 load: 13.4 A</p> <p>Rated current at 1/2 load: 10.9 A</p> <p>Starting current: 107 A</p> <p>Rated current at no load: 7.4 A</p> <p>Cos phi - power factor: 0.79</p> <p>Cos phi - p.f. at no load: 0.12</p> <p>Cos phi - p.f. at 3/4 load: 0.72</p> <p>Cos phi - p.f. at 1/2 load: 0.61</p> <p>Rated speed: 1455 rpm</p> <p>Locked-rotor torque: 91 Nm</p> <p>Breakdown torque: 141 Nm</p> <p>Moment of inertia: 0.0692 kg m²</p> <p>Motor efficiency at full load: 83.4 %</p> <p>Motor efficiency at 3/4 load: 83.5 %</p> <p>Motor efficiency at 1/2 load: 81.3 %</p> <p>Number of poles: 4</p> <p>Start. method: star/delta</p> <p>Enclosure class (IEC 34-5): IP68</p> <p>Insulation class (IEC 85): F</p> <p>Explosion proof: no</p> <p>Length of cable: 10 m</p> <p>Cable type: LYNIFLEX</p> <p>Type of cable plug: NO PLUG</p> <p>Others:</p> <p>Net weight: 190 kg</p> <p>Country of origin: HU</p> <p>Custom tariff no.: 84137021</p>

96177672 SEV.100.100.75.A.4.51D 50 Hz

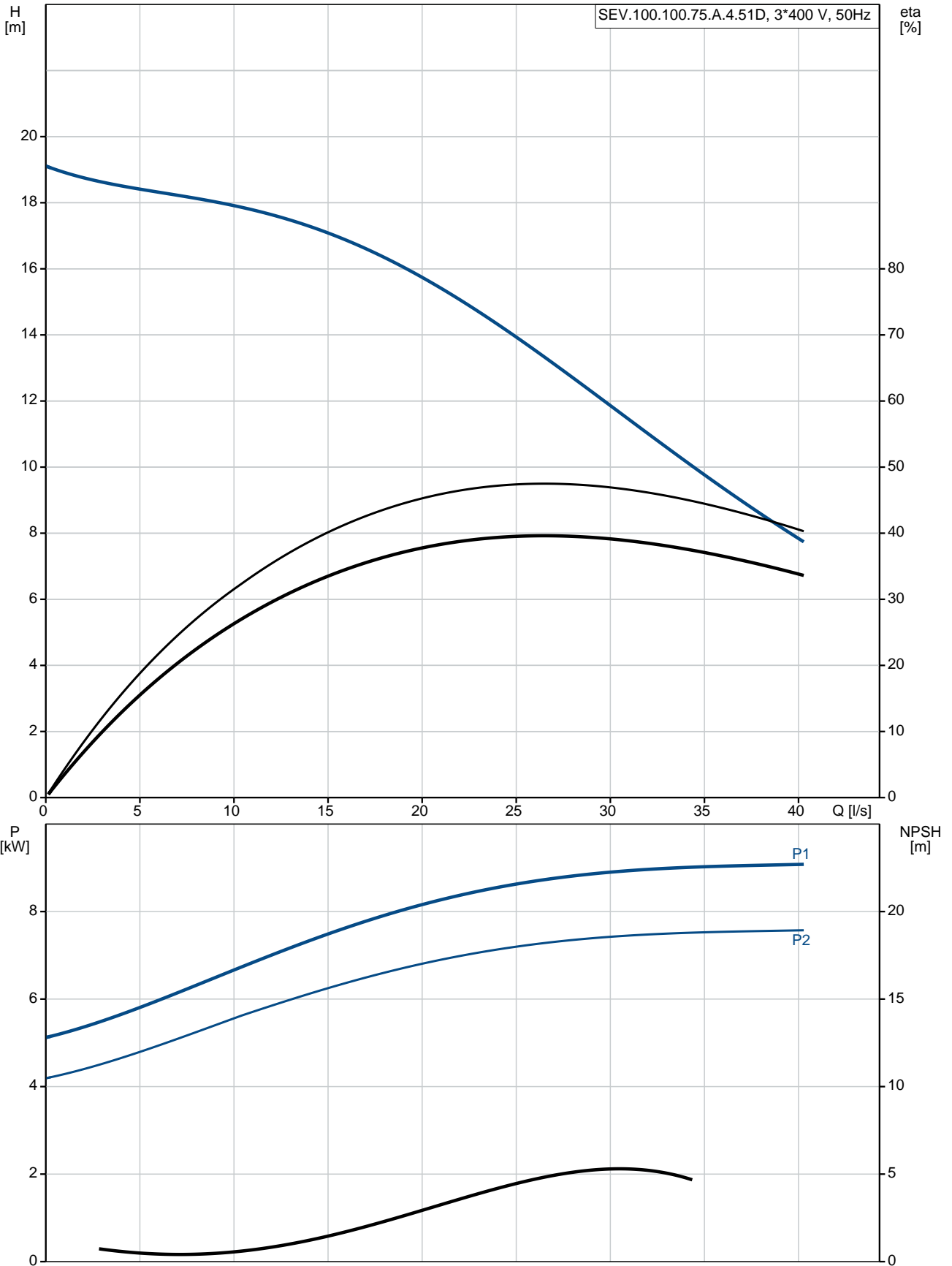

Description	Value
General information:	
Product name:	SEV.100.100.75.A.4.51D
Product No:	96177672
EAN number:	5700830442685
	5700830442685
Price:	5.801,00 GBP
Technical:	
Max flow:	40.3 l/s
Head max:	19.1 m
Type of impeller:	SUPER VORTEX
Maximum particle size:	100 mm
Primary shaft seal:	SIC/SIC
Secondary shaft seal:	CARBON/CERAMICS
Max. hydraulic efficiency:	48 %
Approvals on nameplate:	EN12050-1
Curve tolerance:	ISO9906:2012 3B2
Cooling jacket:	with cooling jacket
Materials:	
Pump housing:	EN 1561 EN-GJL-250
Impeller:	Cast iron
Installation:	
Maximum ambient temperature:	40 °C
Maximum operating pressure:	6 bar
Flange standard:	DIN
Pump outlet:	DN 100
Pressure rating:	PN 10
Maximum installation depth:	20 m
Inst dry/wet:	DRY/SUBMERGED
Installation:	horizontal or vertical
Liquid:	
Pumped liquid:	Any Newtonian liquid
Liquid temperature range:	0 .. 40 °C
Density:	998.2 kg/m ³
Electrical data:	
Power input - P1:	9 kW
Rated power - P2:	7.5 kW
Mains frequency:	50 Hz
Rated voltage:	3 x 380-415 V
Voltage tolerance:	+6/-10 %
Max starts per. hour:	20
Rated current:	17.7-17.5 A
Rated current at 3/4 load:	13.4 A
Rated current at 1/2 load:	10.9 A
Starting current:	107 A
Rated current at no load:	7.4 A
Cos phi - power factor:	0.79
Cos phi - p.f. at no load:	0.12
Cos phi - p.f. at 3/4 load:	0.72
Cos phi - p.f. at 1/2 load:	0.61
Rated speed:	1455 rpm
Locked-rotor torque:	91 Nm
Breakdown torque:	141 Nm
Moment of inertia:	0.0692 kg m ²
Motor efficiency at full load:	83.4 %
Motor efficiency at 3/4 load:	83.5 %
Motor efficiency at 1/2 load:	81.3 %
Number of poles:	4
Start. method:	star/delta

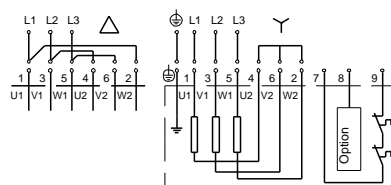
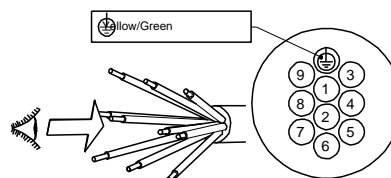
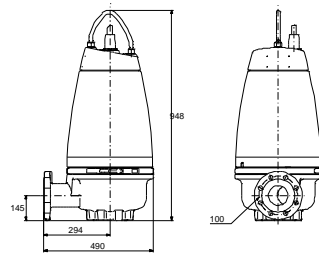
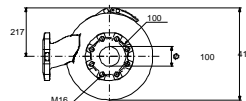
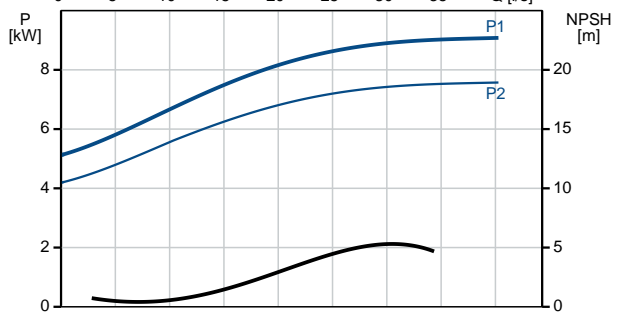
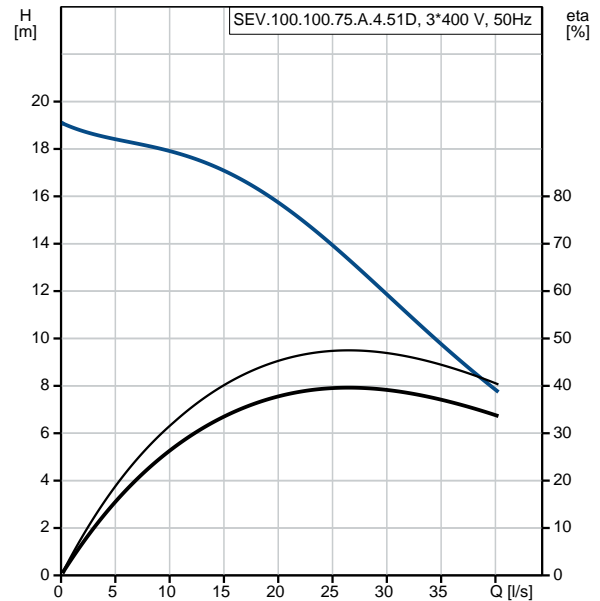



Company name:

Created by:

Phone:

Date:

28/01/2020

Description	Value
Enclosure class (IEC 34-5):	IP68
Insulation class (IEC 85):	F
Explosion proof:	no
Motor protec:	THERMAL SWITCH
Thermal protec:	internal
Length of cable:	10 m
Cable type:	LYNIFLEX
Type of cable plug:	NO PLUG
Controls:	
Control box:	not included
Moisture sensor:	with moisture sensors
Water-in-oil sensor:	with water-in-oil sensor
Temp. sensor:	Y
Others:	
Net weight:	190 kg
Country of origin:	HU
Custom tariff no.:	84137021

96177672 SEV.100.100.75.A.4.51D 50 Hz

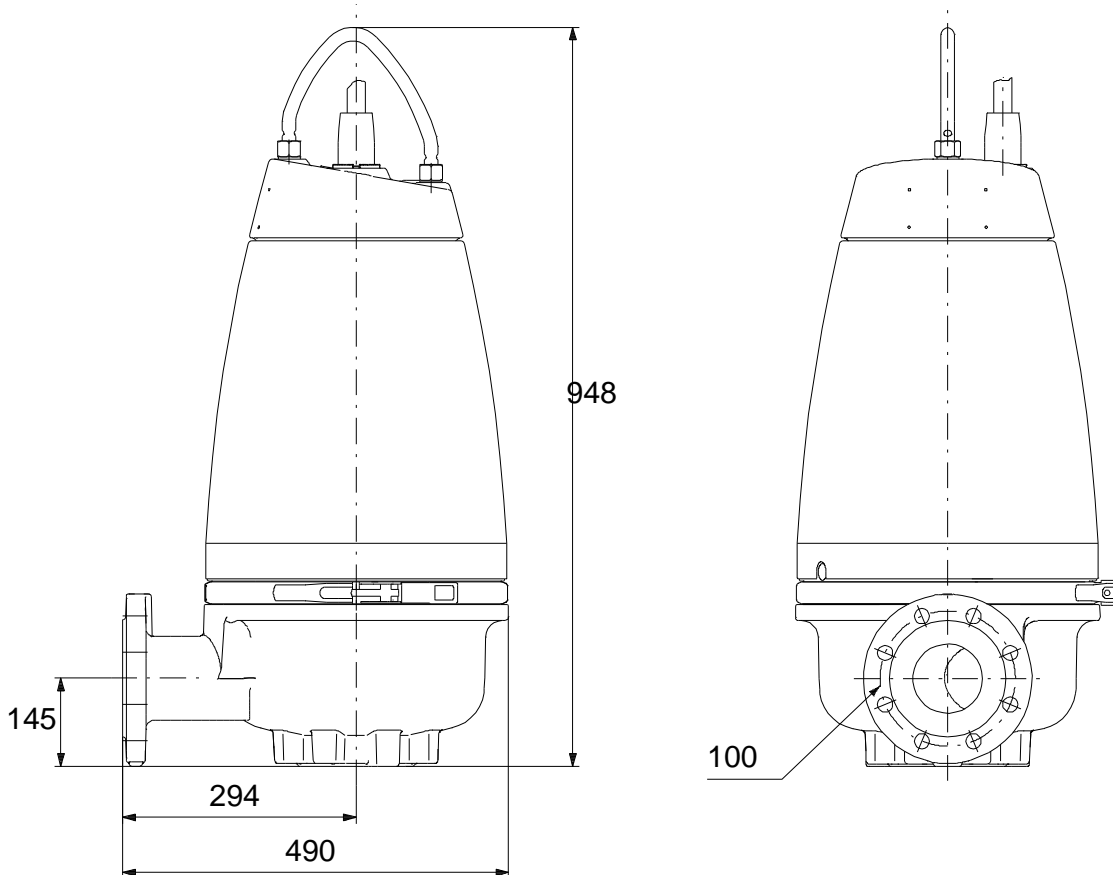
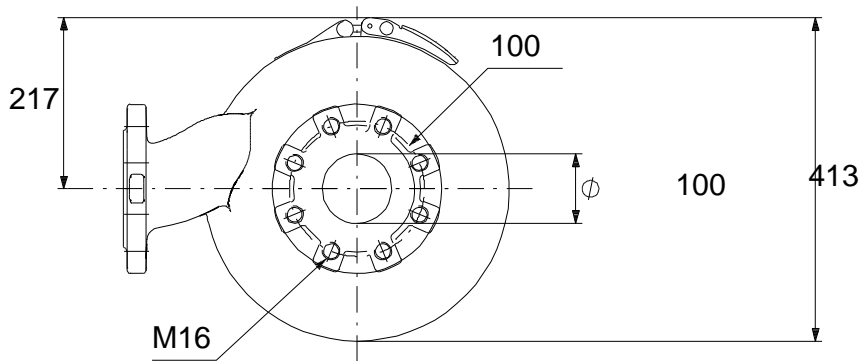

Note! All units are in [mm] unless others are stated.
Disclaimer: This simplified dimensional drawing does not show all details.

96177672 SEV.100.100.75.A.4.51D 50 Hz

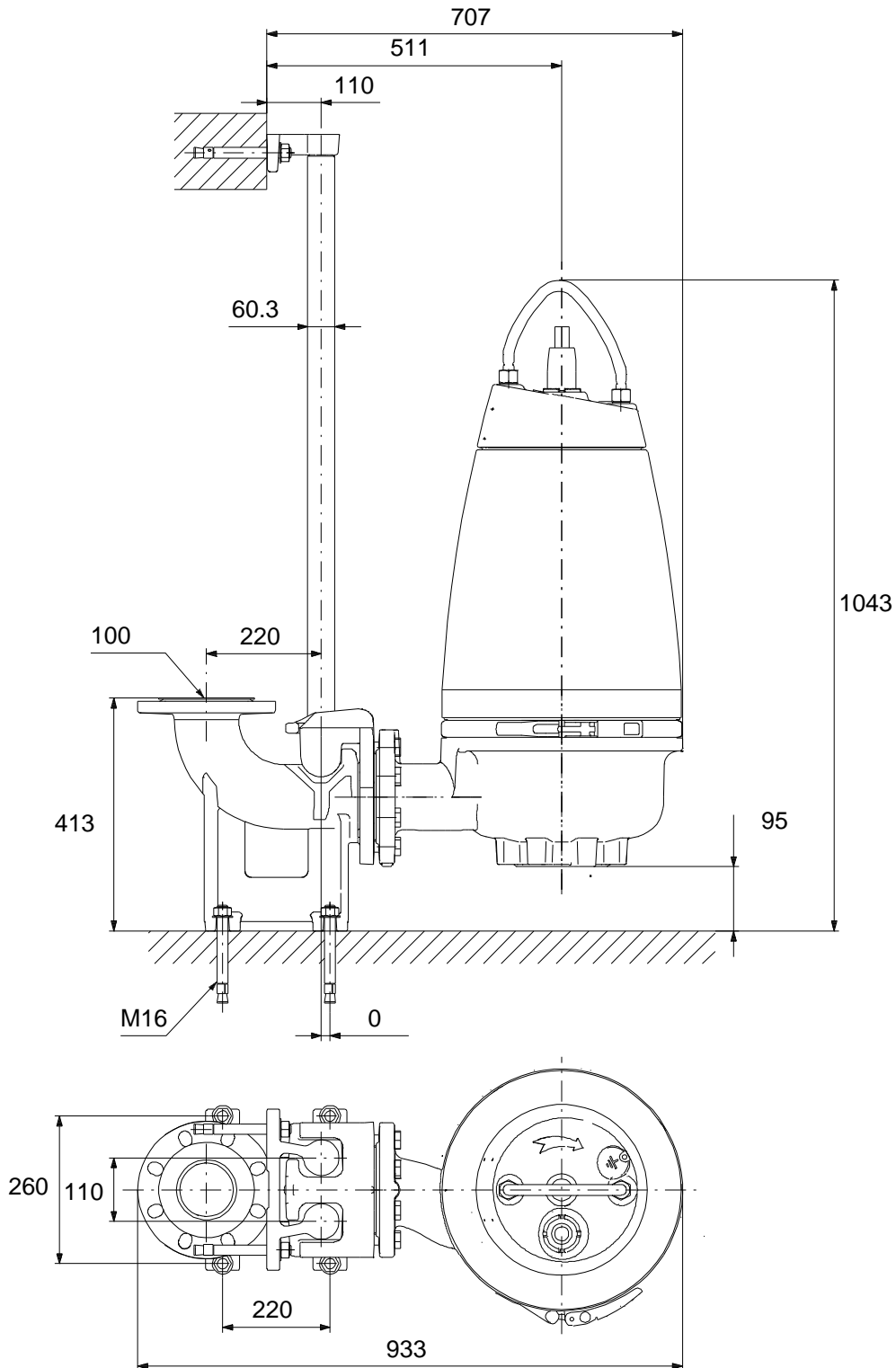

Note! All units are in [mm] unless others are stated.
Disclaimer: This simplified dimensional drawing does not show all details.

96177672 SEV.100.100.75.A.4.51D 50 Hz

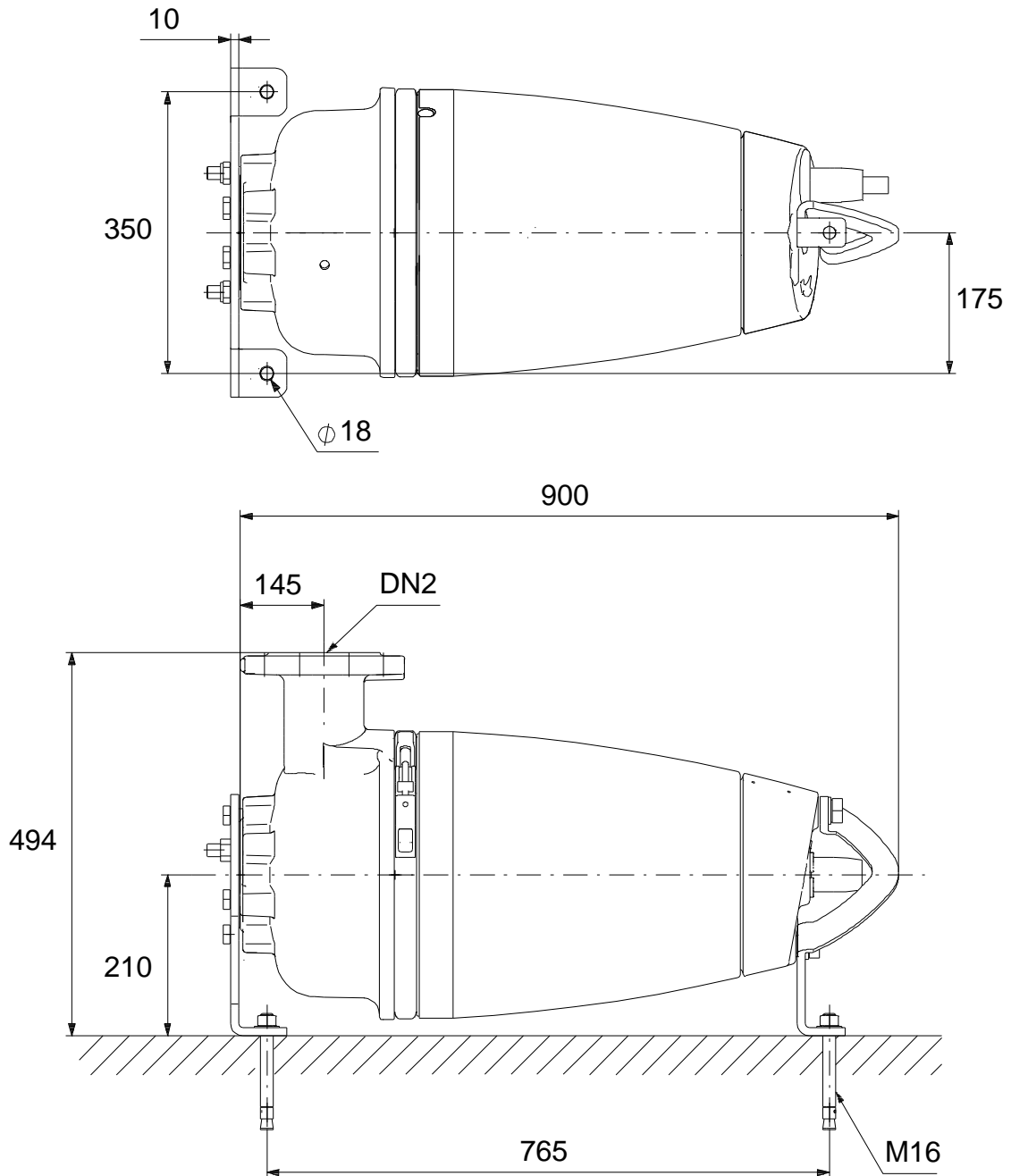

Note! All units are in [mm] unless others are stated.
Disclaimer: This simplified dimensional drawing does not show all details.

96177672 SEV.100.100.75.A.4.51D 50 Hz

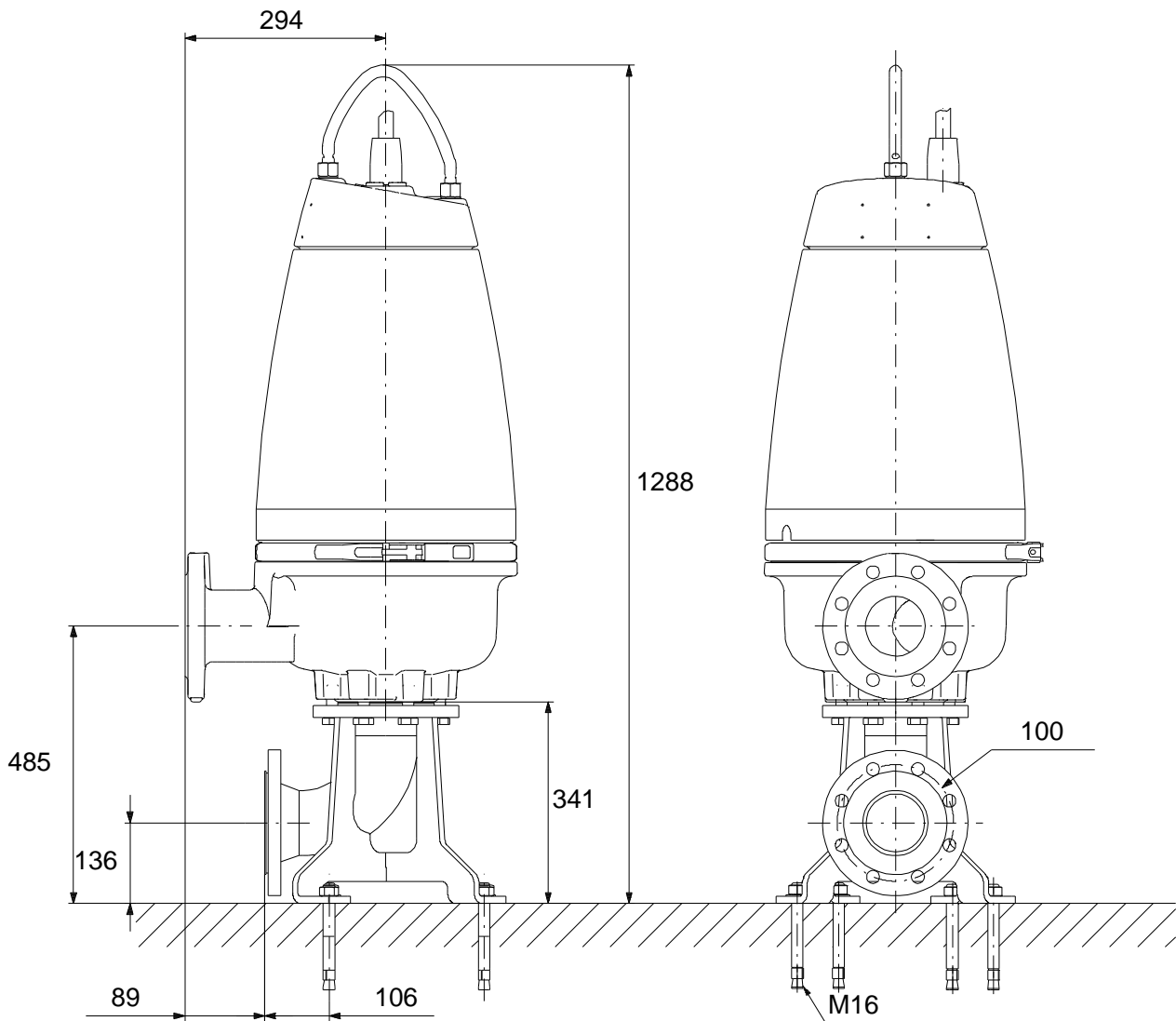
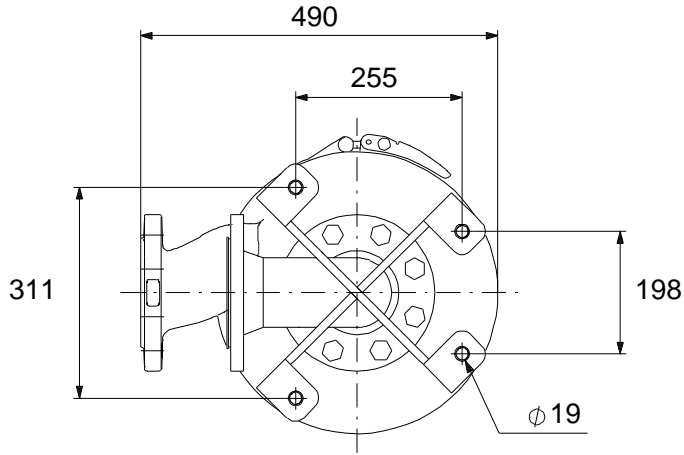

Note! All units are in [mm] unless others are stated.
Disclaimer: This simplified dimensional drawing does not show all details.

96177672 SEV.100.100.75.A.4.51D 50 Hz

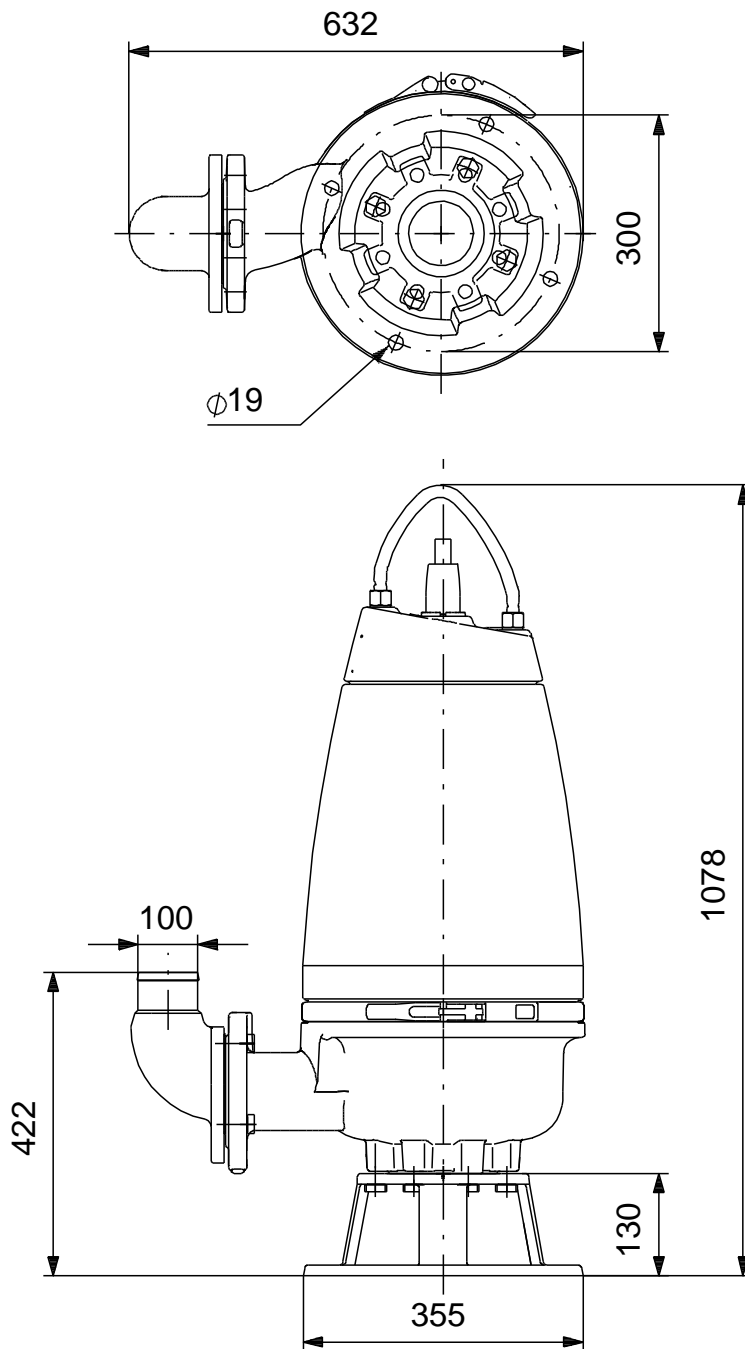

Note! All units are in [mm] unless others are stated.
Disclaimer: This simplified dimensional drawing does not show all details.