

Position	Qty.	Description
	1	<p>TPD 100-480/2 A-F-A-BQQE</p>  <p>Product No.: 96109252</p> <p>Single-stage, close-coupled, volute twin-head pump with in-line suction and discharge ports of identical diameter. The twin-head pump is designed with two parallel power-heads. The pump is of the top-pull-out design, i.e. the power head (motor, pump head and impeller) can be removed for maintenance or service while the pump housing remains in the pipework.</p> <p>Each power head is fitted with an unbalanced rubber bellows seal. The shaft seal is according to EN 12756. Pipework connection is via PN 16 DIN flanges (EN 1092-2 and ISO 7005-2).</p> <p>Each power head is fitted with a fan-cooled asynchronous motor of identical size.</p> <p>Liquid:</p> <p>Pumped liquid: Water Liquid temperature range: -25 .. 120 °C Liquid temperature during operation: 20 °C Density: 998.2 kg/m³</p> <p>Technical:</p> <p>Rated flow: 146 m³/h Rated head: 47.9 m Actual impeller diameter: 200 mm Primary shaft seal: BQQE Curve tolerance: ISO9906:2012 3B</p> <p>Materials:</p> <p>Pump housing: Cast iron EN-JL1040 ASTM A48-40 B</p> <p>Impeller: Cast iron EN-JL1030 ASTM A48-30 B</p> <p>Installation:</p> <p>Range of ambient temperature: -20 .. 55 °C Maximum operating pressure: 16 bar Flange standard: DIN Pipe connection: DN 100 Pump inlet: DN 100 Pump outlet: DN 100 Pressure rating: PN 16 (@): 550 mm Flange size for motor: FF350</p> <p>Electrical data:</p> <p>Motor type: SIEMENS IE Efficiency class: IE3 Rated power - P2: 2 x 30 kW Power (P2) required by pump: 30 kW Mains frequency: 50 Hz</p>

Position	Qty.	Description
		<p>Rated voltage: 3 x 380-420D/660-725Y V</p> <p>Rated current: 56,0-51,0/32,0-29,5 A</p> <p>Starting current: 660-660 %</p> <p>Cos phi - power factor: 0.86</p> <p>Rated speed: 2955 rpm</p> <p>Efficiency: IE3 93,3%</p> <p>Motor efficiency at full load: 93.3-93.3 %</p> <p>Motor efficiency at 3/4 load: 93.6-93.6 %</p> <p>Motor efficiency at 1/2 load: 93.4-93.4 %</p> <p>Number of poles: 2</p> <p>Enclosure class (IEC 34-5): 55 Dust/Jetting</p> <p>Insulation class (IEC 85): F</p> <p>Others:</p> <p>Minimum efficiency index, MEI : 0.65</p> <p>ErP status: EuP Standalone/Prod.</p> <p>Net weight: 701 kg</p> <p>Gross weight: 809 kg</p> <p>Shipping volume: 1.8 m³</p> <p>Country of origin: HU</p> <p>Custom tariff no.: 84137065</p>

96109252 TPD 100-480/2 A-F-A-BQQE 50 Hz

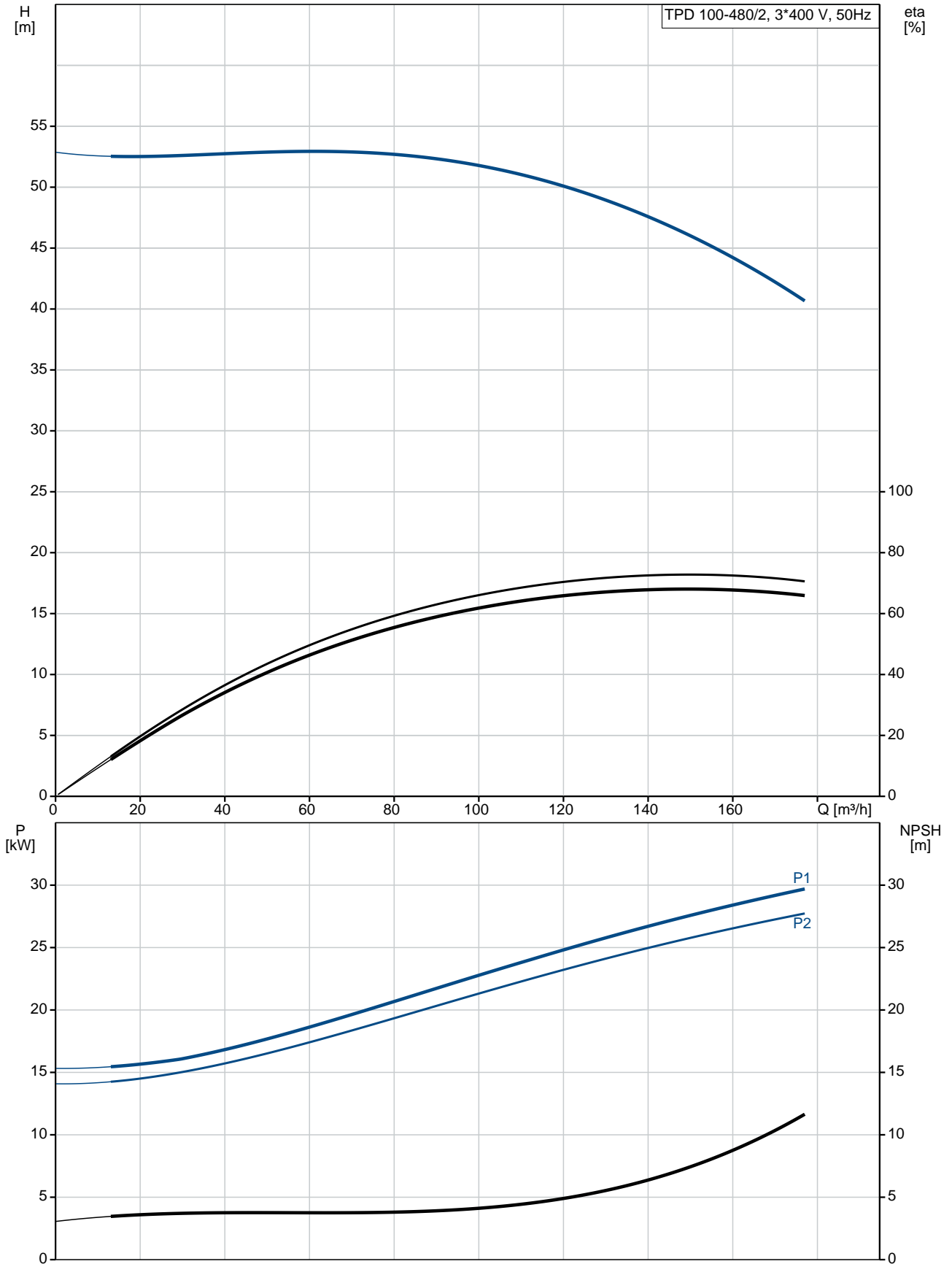

Description	Value
General information:	
Product name:	TPD 100-480/2 A-F-A-BQQE
Product No:	96109252
EAN number:	5700396982298
Technical:	
Rated flow:	146 m ³ /h
Rated head:	47.9 m
Head max:	480 dm
Actual impeller diameter:	200 mm
Primary shaft seal:	BQQE
Curve tolerance:	ISO9906:2012 3B
Pump version:	A
Model:	A
Materials:	
Pump housing:	Cast iron EN-JL1040 ASTM A48-40 B
Impeller:	Cast iron EN-JL1030 ASTM A48-30 B
Material code:	A
Installation:	
Range of ambient temperature:	-20 .. 55 °C
Maximum operating pressure:	16 bar
Flange standard:	DIN
Pipe connection:	DN 100
Pump inlet:	DN 100
Pump outlet:	DN 100
Pressure rating:	PN 16
(@)	550 mm
Flange size for motor:	FF350
Connect code:	F
Liquid:	
Pumped liquid:	Water
Liquid temperature range:	-25 .. 120 °C
Liquid temperature during operation:	20 °C
Density:	998.2 kg/m ³
Electrical data:	
Motor type:	SIEMENS
IE Efficiency class:	IE3
Rated power - P2:	2 x 30 kW
Power (P2) required by pump:	30 kW
Mains frequency:	50 Hz
Rated voltage:	3 x 380-420D/660-725Y V
Rated current:	56,0-51,0/32,0-29,5 A
Starting current:	660-660 %
Cos phi - power factor:	0.86
Rated speed:	2955 rpm
Efficiency:	IE3 93,3%
Motor efficiency at full load:	93.3-93.3 %
Motor efficiency at 3/4 load:	93.6-93.6 %
Motor efficiency at 1/2 load:	93.4-93.4 %
Number of poles:	2
Enclosure class (IEC 34-5):	55 Dust/Jetting
Insulation class (IEC 85):	F
Motor protec:	PTC
Motor No:	99032179

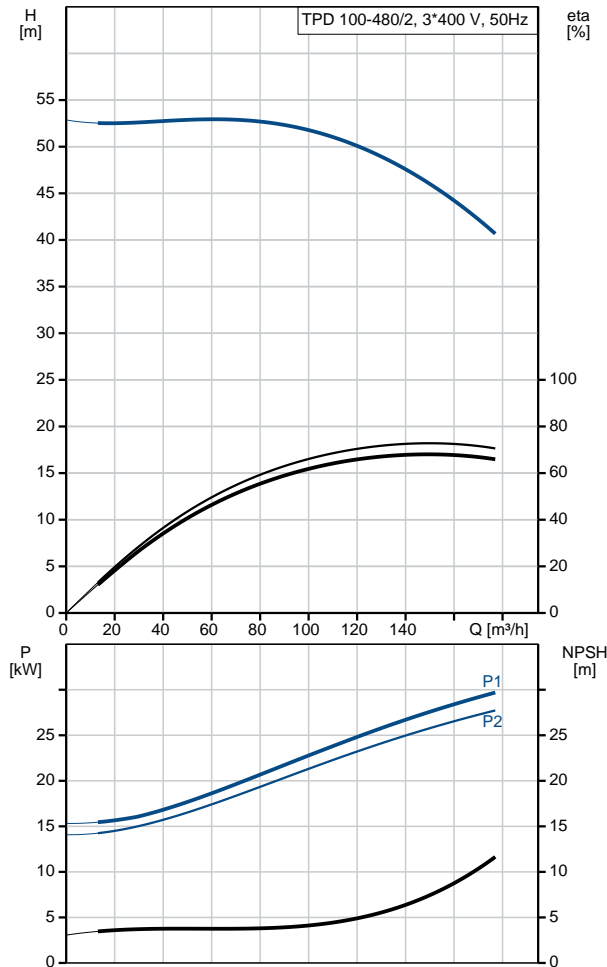



Company name:

Created by:

Phone:

Date:

11/10/2018

Description	Value
Others:	
Minimum efficiency index, MEI :	0.65
ErP status:	EuP Standalone/Prod.
Net weight:	701 kg
Gross weight:	809 kg
Shipping volume:	1.8 m ³
Country of origin:	HU
Custom tariff no.:	84137065

96109252 TPD 100-480/2 A-F-A-BQQE 50 Hz

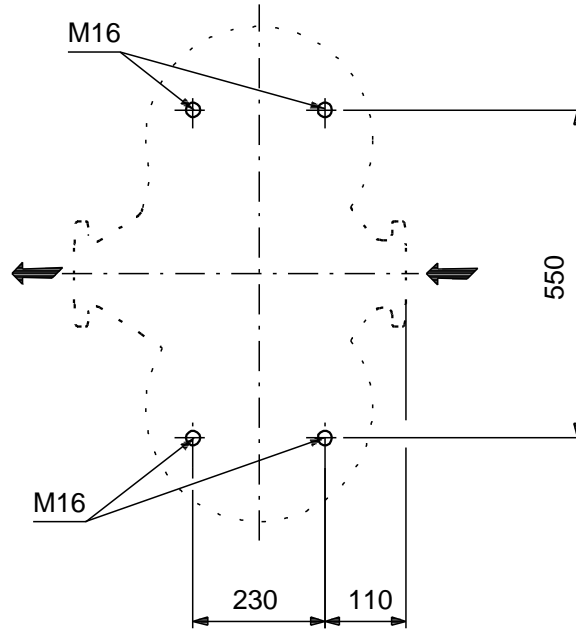
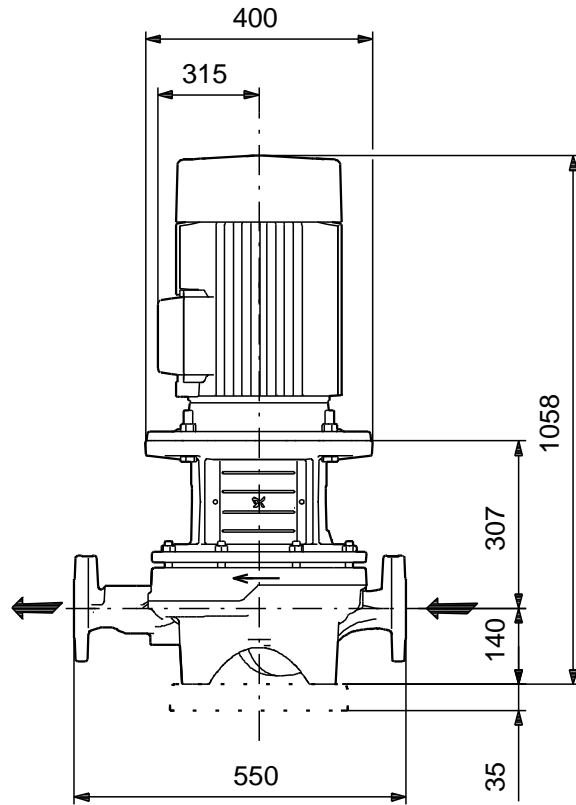
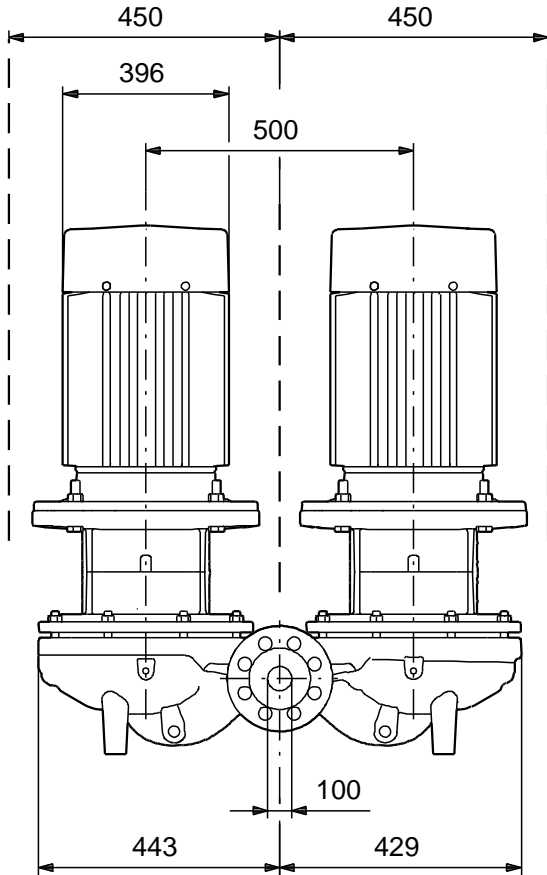

Note! All units are in [mm] unless others are stated.
Disclaimer: This simplified dimensional drawing does not show all details.

96109252 TPD 100-480/2 A-F-A-BQQE 50 Hz



IEC TP211 THERMALLY PROTECTED WHEN THE THERMISTORS ARE
CONNECTED TO AMPLIFIER RELAY FOR CONTROL OF MAIN SUPPLY
THERMISTORS PTC ACCORDING TO DIN 44082

Note! All units are in [mm] unless others are stated.