

Position	Qty.	Description
	1	<p><b>TPD 100-70/4 A-F-A-BQQE</b></p>  <p>Product No.: <a href="#">96109123</a></p> <p>Single-stage, close-coupled, volute twin-head pump with in-line suction and discharge ports of identical diameter. The twin-head pump is designed with two parallel power-heads. The pump is of the top-pull-out design, i.e. the power head (motor, pump head and impeller) can be removed for maintenance or service while the pump housing remains in the pipework.</p> <p>Each power head is fitted with an unbalanced rubber bellows seal. The shaft seal is according to EN 12756. Pipework connection is via PN 16 DIN flanges (EN 1092-2 and ISO 7005-2).</p> <p>Each power head is fitted with a fan-cooled asynchronous motor of identical size.</p> <p><b>Liquid:</b></p> <p>Pumped liquid: Water            Liquid temperature range: -25 .. 120 °C            Liquid temperature during operation: 20 °C            Density: 998.2 kg/m<sup>3</sup></p> <p><b>Technical:</b></p> <p>Rated flow: 79.1 m<sup>3</sup>/h            Rated head: 4.79 m            Actual impeller diameter: 150 mm            Primary shaft seal: BQQE            Curve tolerance: ISO9906:2012 3B</p> <p><b>Materials:</b></p> <p>Pump housing: Cast iron            EN-JL1040            ASTM A48-40 B</p> <p>Impeller: Cast iron            EN-JL1030            ASTM A48-30 B</p> <p><b>Installation:</b></p> <p>Range of ambient temperature: -30 .. 60 °C            Maximum operating pressure: 16 bar            Flange standard: DIN            Pipe connection: DN 100            Pump inlet: DN 100            Pump outlet: DN 100            Pressure rating: PN 16            (@): 550 mm            Flange size for motor: FF165</p> <p><b>Electrical data:</b></p> <p>Motor type: 90LC            IE Efficiency class: IE3            Rated power - P2: 2 x 1.5 kW            Power (P2) required by pump: 1.5 kW            Mains frequency: 50 Hz</p>

Position	Qty.	Description
		<p>Rated voltage: 3 x 220-240D/380-415Y V</p> <p>Rated current: 6,15-6,30/3,55-3,65 A</p> <p>Starting current: 730-790 %</p> <p>Cos phi - power factor: 0.75-0.68</p> <p>Rated speed: 1450-1460 rpm</p> <p>Efficiency: IE3 85,3%</p> <p>Motor efficiency at full load: 85.3 %</p> <p>Motor efficiency at 3/4 load: 85.8 %</p> <p>Motor efficiency at 1/2 load: 84.2 %</p> <p>Number of poles: 4</p> <p>Enclosure class (IEC 34-5): 55 Dust/Jetting</p> <p>Insulation class (IEC 85): F</p> <p><b>Others:</b></p> <p>Minimum efficiency index, MEI : 0.70</p> <p>ErP status: EuP Standalone/Prod.</p> <p>Net weight: 195 kg</p> <p>Gross weight: 215 kg</p> <p>Shipping volume: 1.12 m<sup>3</sup></p>

## 96109123 TPD 100-70/4 A-F-A-BQQE 50 Hz

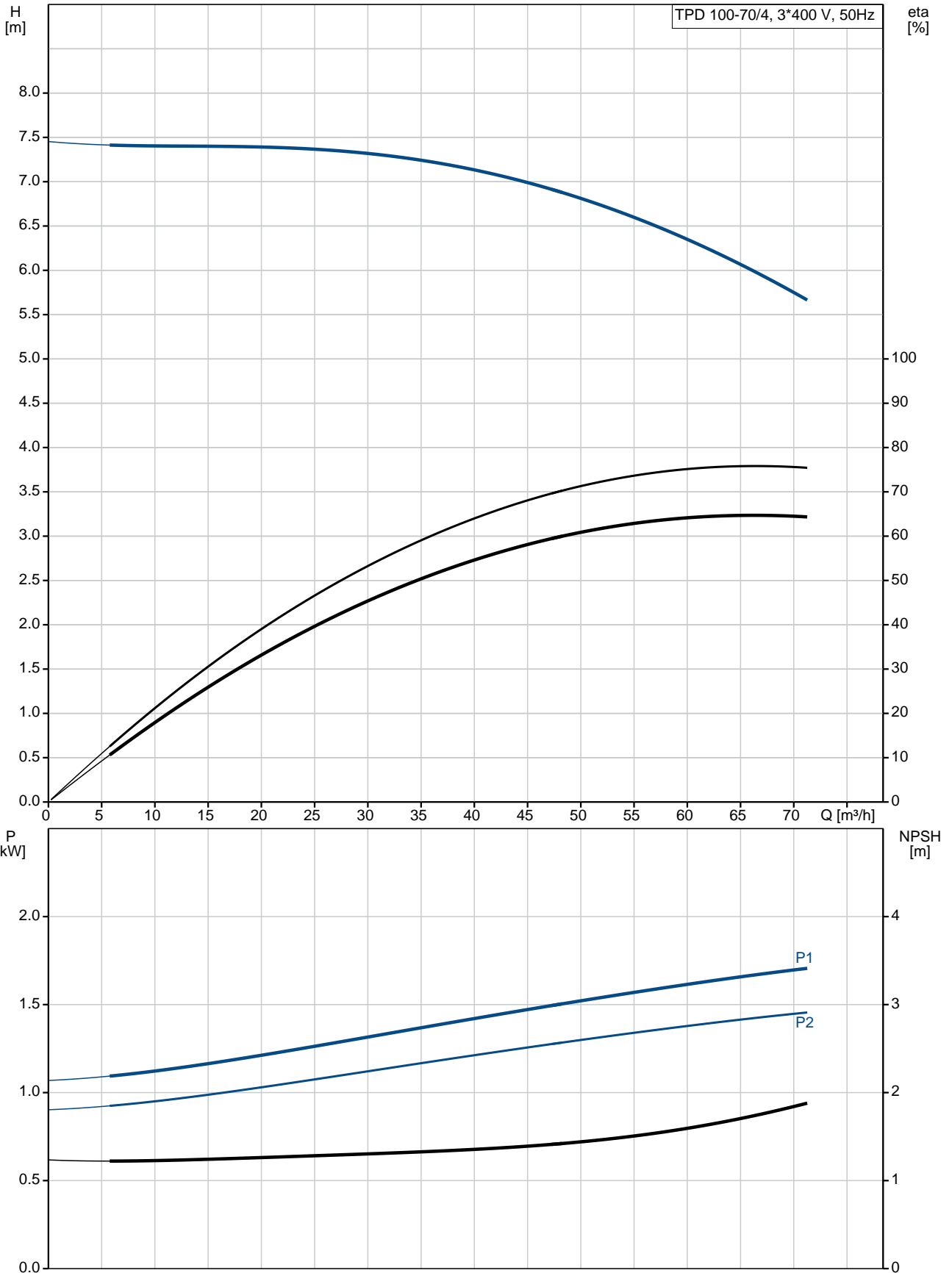

Description	Value
<b>General information:</b>	
Product name:	TPD 100-70/4 A-F-A-BQQE
Product No:	96109123
EAN number:	5700396980904
<b>Technical:</b>	
Rated flow:	79.1 m <sup>3</sup> /h
Rated head:	4.79 m
Head max:	70 dm
Actual impeller diameter:	150 mm
Primary shaft seal:	BQQE
Curve tolerance:	ISO9906:2012 3B
Pump version:	A
Model:	A
<b>Materials:</b>	
Pump housing:	Cast iron EN-JL1040 ASTM A48-40 B
Impeller:	Cast iron EN-JL1030 ASTM A48-30 B
Material code:	A
<b>Installation:</b>	
Range of ambient temperature:	-30 .. 60 °C
Maximum operating pressure:	16 bar
Flange standard:	DIN
Pipe connection:	DN 100
Pump inlet:	DN 100
Pump outlet:	DN 100
Pressure rating:	PN 16
(@)	550 mm
Flange size for motor:	FF165
Connect code:	F
<b>Liquid:</b>	
Pumped liquid:	Water
Liquid temperature range:	-25 .. 120 °C
Liquid temperature during operation:	20 °C
Density:	998.2 kg/m <sup>3</sup>
<b>Electrical data:</b>	
Motor type:	90LC
IE Efficiency class:	IE3
Rated power - P2:	2 x 1.5 kW
Power (P2) required by pump:	1.5 kW
Mains frequency:	50 Hz
Rated voltage:	3 x 220-240D/380-415Y V
Rated current:	6,15-6,30/3,55-3,65 A
Starting current:	730-790 %
Cos phi - power factor:	0.75-0.68
Rated speed:	1450-1460 rpm
Efficiency:	IE3 85,3%
Motor efficiency at full load:	85.3 %
Motor efficiency at 3/4 load:	85.8 %
Motor efficiency at 1/2 load:	84.2 %
Number of poles:	4
Enclosure class (IEC 34-5):	55 Dust/Jetting
Insulation class (IEC 85):	F
Motor protec:	NONE
Motor No:	87220319
<b>Others:</b>	

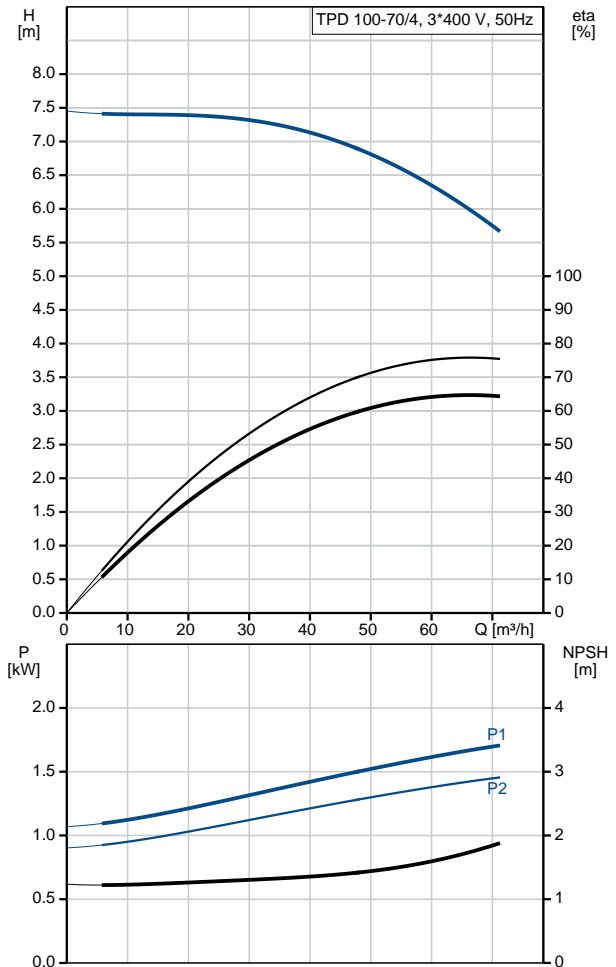



Company name:

Created by:

Phone:

Date:

05/10/2018

Description	Value
Minimum efficiency index, MEI :	0.70
ErP status:	EuP Standalone/Prod.
Net weight:	195 kg
Gross weight:	215 kg
Shipping volume:	1.12 m <sup>3</sup>

## 96109123 TPD 100-70/4 A-F-A-BQQE 50 Hz

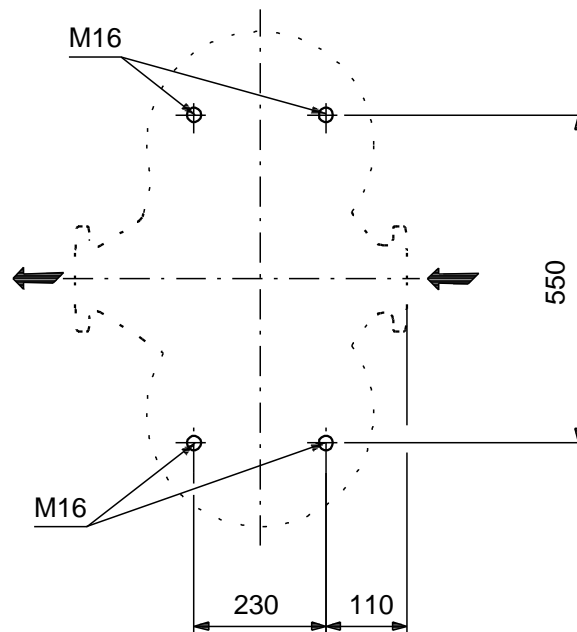
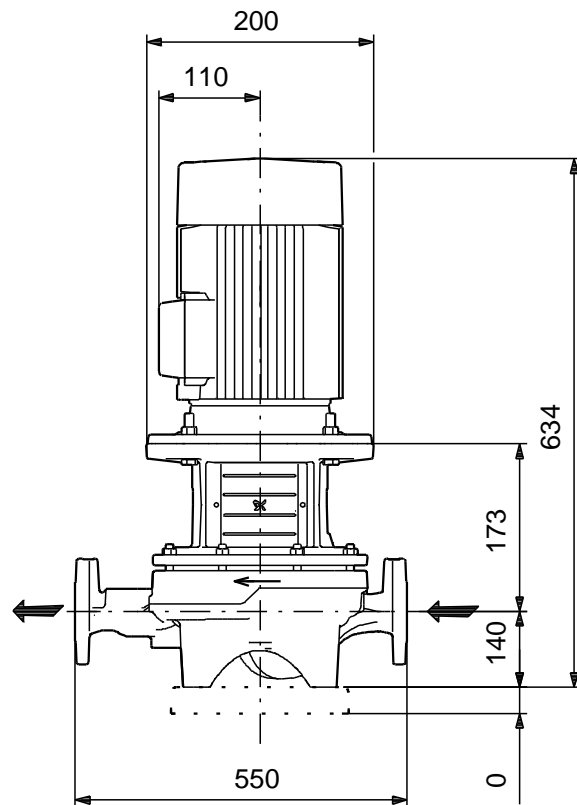
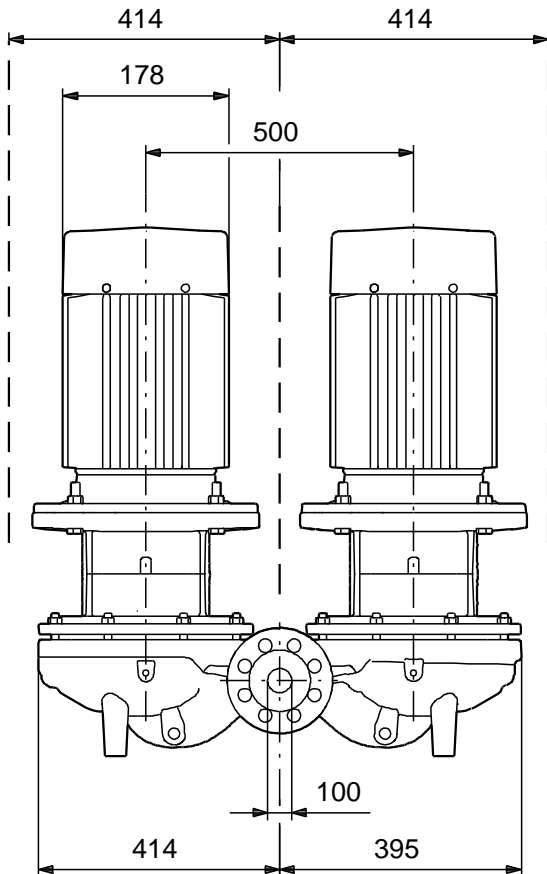

Note! All units are in [mm] unless others are stated.  
Disclaimer: This simplified dimensional drawing does not show all details.

**96109123 TPD 100-70/4 A-F-A-BQQE 50 Hz**



Note! All units are in [mm] unless others are stated.