

Position	Qty.	Description
	1	<p>TPD 80-340/4 A-F-A-BQQE</p>  <p>Product No.: 96108896</p> <p>Single-stage, close-coupled, volute twin-head pump with in-line suction and discharge ports of identical diameter. The twin-head pump is designed with two parallel power-heads. The pump is of the top-pull-out design, i.e. the power head (motor, pump head and impeller) can be removed for maintenance or service while the pump housing remains in the pipework.</p> <p>Each power head is fitted with an unbalanced rubber bellows seal. The shaft seal is according to EN 12756. Pipework connection is via PN 16 DIN flanges (EN 1092-2 and ISO 7005-2).</p> <p>Each power head is fitted with a fan-cooled asynchronous motor of identical size.</p> <p>Liquid:</p> <p>Pumped liquid: Water Liquid temperature range: -25 .. 120 °C Liquid temperature during operation: 20 °C Density: 998.2 kg/m³</p> <p>Technical:</p> <p>Rated flow: 80.9 m³/h Rated head: 28.3 m Actual impeller diameter: 309 mm Primary shaft seal: BQQE Curve tolerance: ISO9906:2012 3B</p> <p>Materials:</p> <p>Pump housing: Cast iron EN-JL1040 ASTM A48-40 B</p> <p>Impeller: Cast iron EN-JL1030 ASTM A48-30 B</p> <p>Installation:</p> <p>Range of ambient temperature: -30 .. 60 °C Maximum operating pressure: 16 bar Flange standard: DIN Pipe connection: DN 80 Pump inlet: DN 80 Pump outlet: DN 80 Pressure rating: PN 16 (@): 620 mm Flange size for motor: FF300</p> <p>Electrical data:</p> <p>Motor type: 160MA IE Efficiency class: IE3 Rated power - P2: 2 x 11 kW Power (P2) required by pump: 11 kW Mains frequency: 50 Hz</p>

Position	Qty.	Description
		<p>Rated voltage: 3 x 380-415D/660-690Y V</p> <p>Rated current: 21,2-20,4/12,2-12,0 A</p> <p>Starting current: 710-810 %</p> <p>Cos phi - power factor: 0.86-0.81</p> <p>Rated speed: 1470-1475 rpm</p> <p>Efficiency: IE3 91,4%</p> <p>Motor efficiency at full load: 91.4 %</p> <p>Motor efficiency at 3/4 load: 92.1 %</p> <p>Motor efficiency at 1/2 load: 91.6 %</p> <p>Number of poles: 4</p> <p>Enclosure class (IEC 34-5): 55 Dust/Jetting</p> <p>Insulation class (IEC 85): F</p> <p>Others:</p> <p>Minimum efficiency index, MEI : 0.70</p> <p>ErP status: EuP Standalone/Prod.</p> <p>Net weight: 500 kg</p> <p>Gross weight: 531 kg</p> <p>Shipping volume: 1.52 m³</p>

96108896 TPD 80-340/4 A-F-A-BQQE 50 Hz

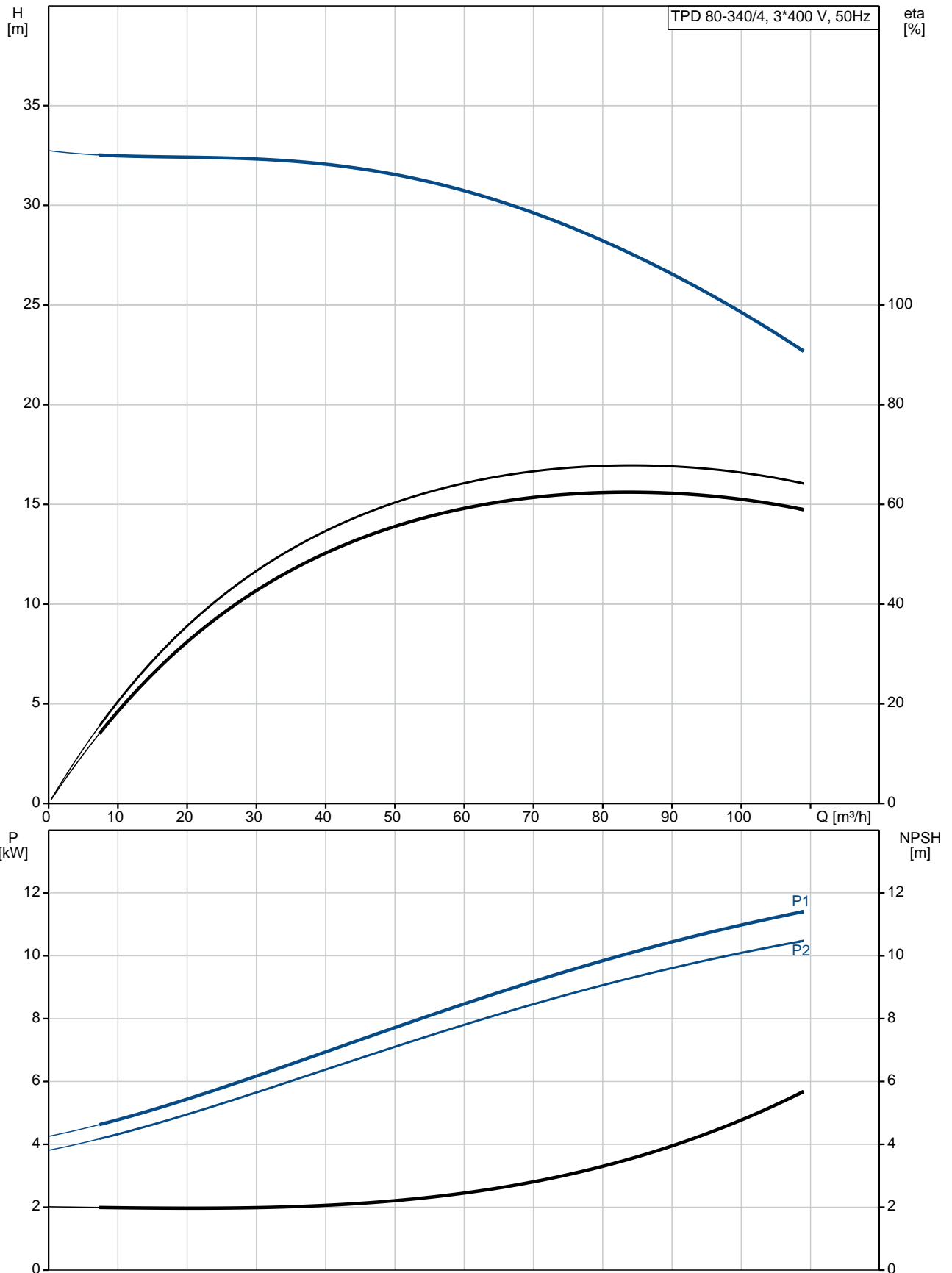

Description	Value
General information:	
Product name:	TPD 80-340/4 A-F-A-BQQE
Product No:	96108896
EAN number:	5700396978628
Technical:	
Rated flow:	80.9 m ³ /h
Rated head:	28.3 m
Head max:	340 dm
Actual impeller diameter:	309 mm
Primary shaft seal:	BQQE
Curve tolerance:	ISO9906:2012 3B
Pump version:	A
Model:	A
Materials:	
Pump housing:	Cast iron EN-JL1040 ASTM A48-40 B
Impeller:	Cast iron EN-JL1030 ASTM A48-30 B
Material code:	A
Installation:	
Range of ambient temperature:	-30 .. 60 °C
Maximum operating pressure:	16 bar
Flange standard:	DIN
Pipe connection:	DN 80
Pump inlet:	DN 80
Pump outlet:	DN 80
Pressure rating:	PN 16
(@)	620 mm
Flange size for motor:	FF300
Connect code:	F
Liquid:	
Pumped liquid:	Water
Liquid temperature range:	-25 .. 120 °C
Liquid temperature during operation:	20 °C
Density:	998.2 kg/m ³
Electrical data:	
Motor type:	160MA
IE Efficiency class:	IE3
Rated power - P2:	2 x 11 kW
Power (P2) required by pump:	11 kW
Mains frequency:	50 Hz
Rated voltage:	3 x 380-415D/660-690Y V
Rated current:	21,2-20,4/12,2-12,0 A
Starting current:	710-810 %
Cos phi - power factor:	0.86-0.81
Rated speed:	1470-1475 rpm
Efficiency:	IE3 91,4%
Motor efficiency at full load:	91.4 %
Motor efficiency at 3/4 load:	92.1 %
Motor efficiency at 1/2 load:	91.6 %
Number of poles:	4
Enclosure class (IEC 34-5):	55 Dust/Jetting
Insulation class (IEC 85):	F
Motor protec:	PTC
Motor No:	87420031
Others:	

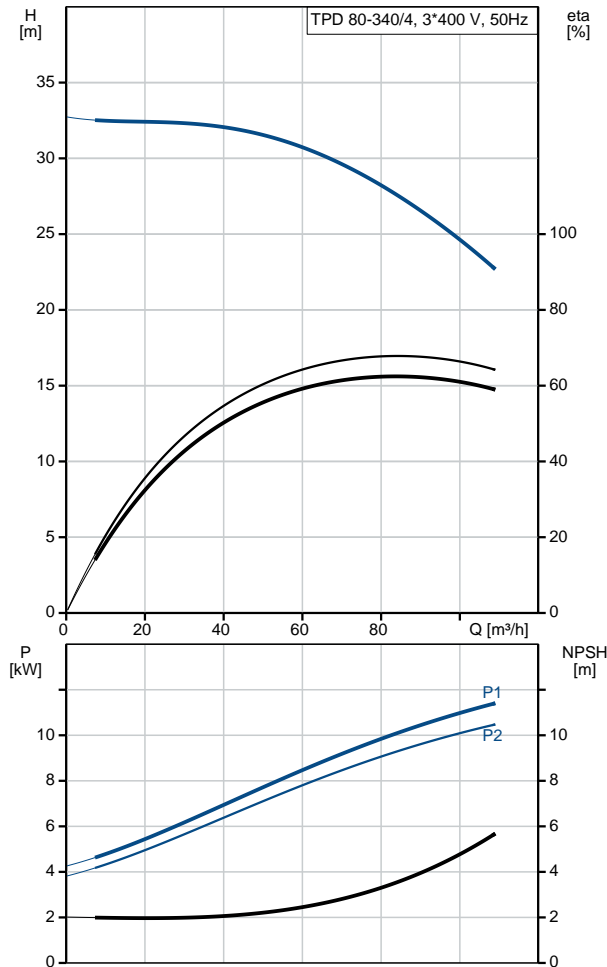



Company name:

Created by:

Phone:

Date:

05/10/2018

Description	Value
Minimum efficiency index, MEI :	0.70
ErP status:	EuP Standalone/Prod.
Net weight:	500 kg
Gross weight:	531 kg
Shipping volume:	1.52 m ³

96108896 TPD 80-340/4 A-F-A-BQQE 50 Hz

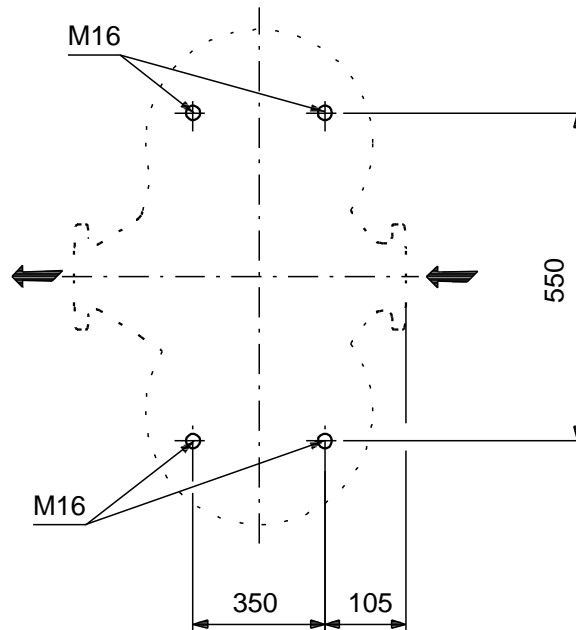
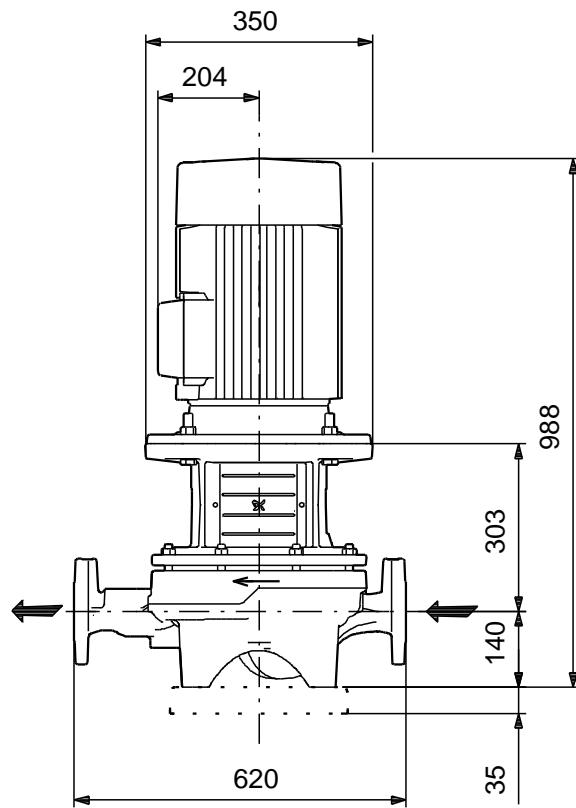
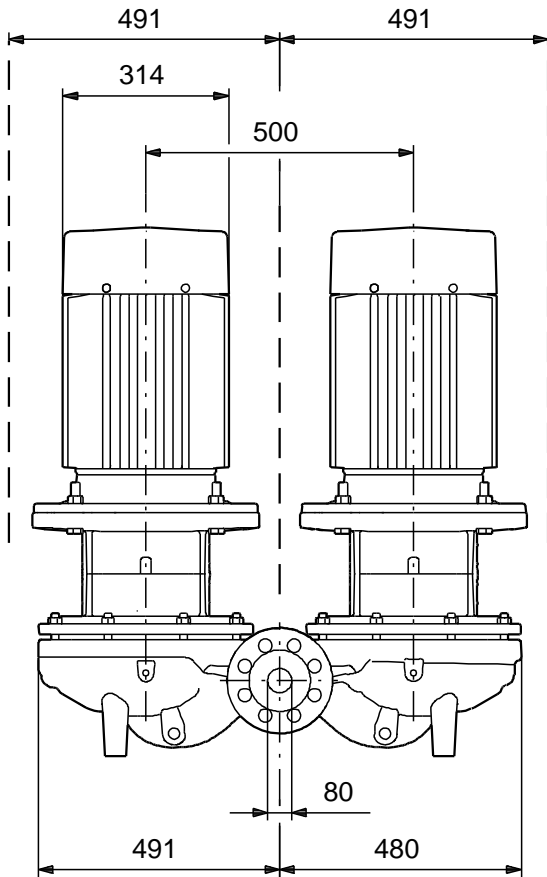

Note! All units are in [mm] unless others are stated.
Disclaimer: This simplified dimensional drawing does not show all details.

96108896 TPD 80-340/4 A-F-A-BQQE 50 Hz

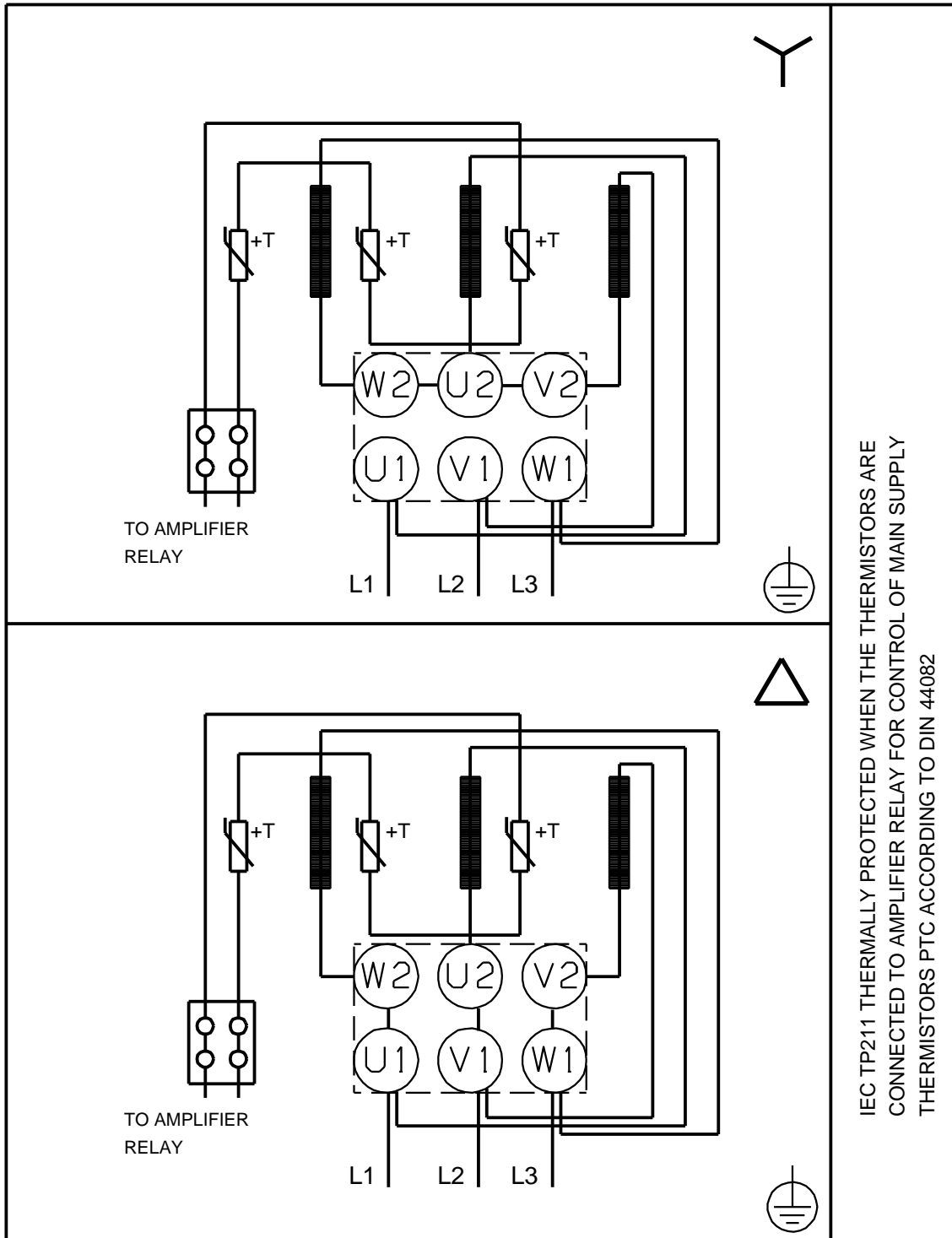

IEC TP211 THERMALLY PROTECTED WHEN THE THERMISTORS ARE
CONNECTED TO AMPLIFIER RELAY FOR CONTROL OF MAIN SUPPLY
THERMISTORS PTC ACCORDING TO DIN 44082

Note! All units are in [mm] unless others are stated.