

Position	Count	Description
	1	<p>TPD 80-110/4 A-F-A-BQQE</p>  <p>Product No.: 96108891</p> <p>Single-stage, close-coupled, volute twin-head pump with in-line suction and discharge ports of identical diameter. The twin-head pump is designed with two parallel power-heads. The pump is of the top-pull-out design, i.e. the power head (motor, pump head and impeller) can be removed for maintenance or service while the pump housing remains in the pipework.</p> <p>Each power head is fitted with an unbalanced rubber bellows seal. The shaft seal is according to EN 12756. Pipework connection is via PN 16 DIN flanges (EN 1092-2 and ISO 7005-2).</p> <p>Each power head is fitted with a fan-cooled asynchronous motor of indential size.</p> <p>Liquid: Pumped liquid: Water Liquid temperature range: -13 .. 248 °F Liquid temperature during operation: 68 °F Density: 62.29 lb/ft³</p> <p>Technical: Rated flow: 219 US gpm Rated head: 29.53 ft Actual impeller diameter: 6.97 in Primary shaft seal: BQQE Curve tolerance: ISO9906:2012 3B</p> <p>Materials: Pump housing: Cast iron EN-JL1040 ASTM A48-40 B Impeller: Cast iron EN-JL1030 ASTM A48-30 B</p> <p>Installation: Range of ambient temperature: -22 .. 140 °F Maximum operating pressure: 232 psi Flange standard: DIN Pipe connection: DN 80 Pump inlet: DN 80 Pump outlet: DN 80 Pressure stage: PN 16 (@): 17 3/8 in Flange size for motor: FF215</p> <p>Electrical data: Motor type: 100LB IE Efficiency class: IE3 Rated power - P2: 2 x 3 HP Power (P2) required by pump: 3 HP Main frequency: 50 Hz</p>



Company name:

Created by:

Phone:

Date:

10/9/2018

Position	Count	Description
		Rated voltage: 3 x 380-415D V Rated current: 4.9 A Starting current: 600-660 % Cos phi - power factor: 0.79-0.73 Rated speed: 1450 rpm IE efficiency: IE3 86,7% Motor efficiency at full load: 86.7 % Motor efficiency at 3/4 load: 87.7 % Motor efficiency at 1/2 load: 87.6 % Number of poles: 4 Enclosure class (IEC 34-5): 55 Dust/Jetting Insulation class (IEC 85): F Others: Minimum efficiency index, MEI : 0.68 ErP status: EuP Standalone/Prod. Net weight: 364 lb Gross weight: 388 lb Shipping volume: 16.2 ft ³ Country of origin: HU Custom tariff no.: 84137065

96108891 TPD 80-110/4 A-F-A-BQQE 50 Hz

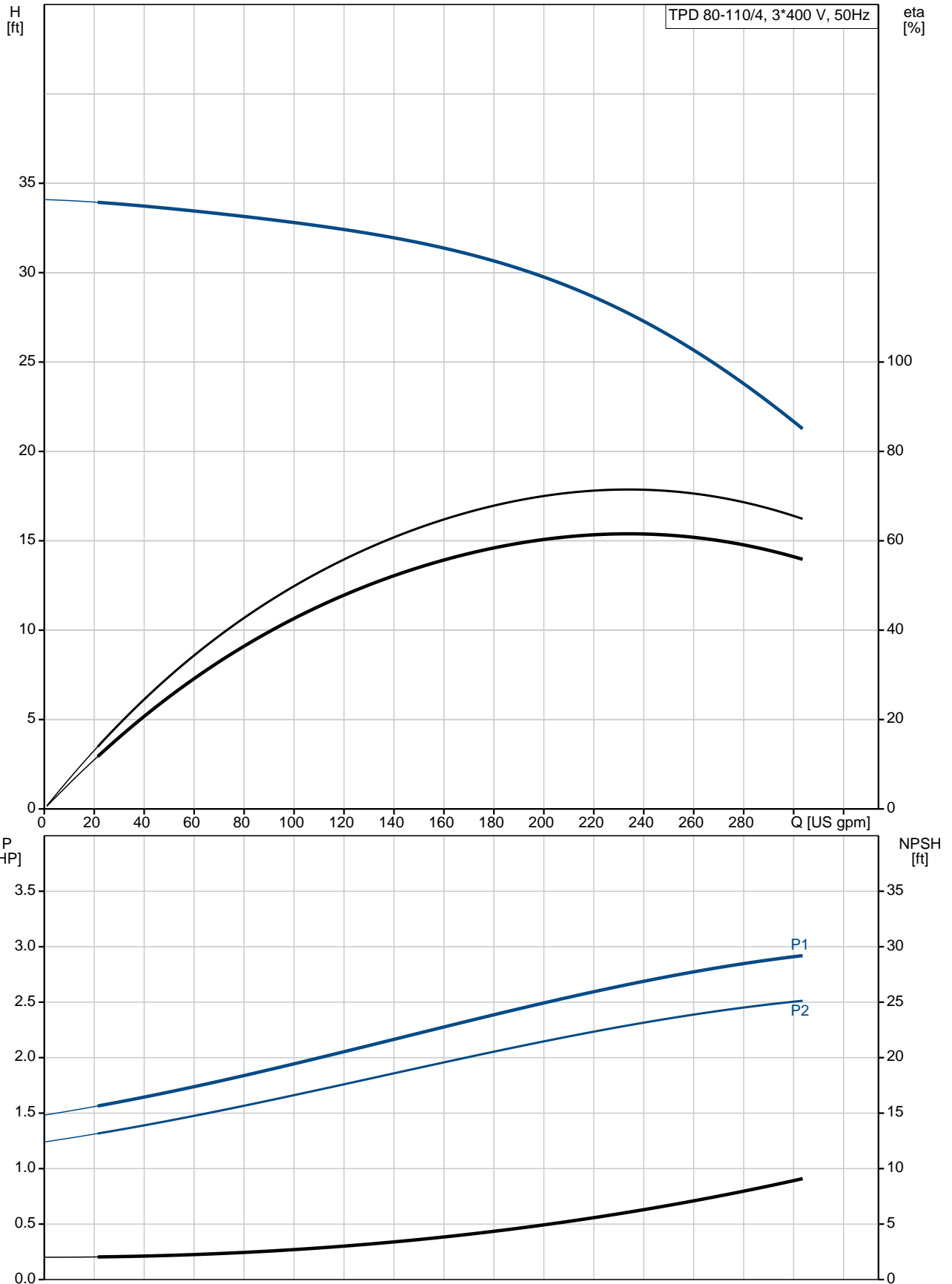

Description	Value
General information:	
Product name:	TPD 80-110/4 A-F-A-BQQE
Product No.:	96108891
EAN:	5700396978574
Technical:	
Rated flow:	219 US gpm
Rated head:	29.53 ft
Head max:	36.09 ft
Actual impeller diameter:	6.97 in
Primary shaft seal:	BQQE
Curve tolerance:	ISO9906:2012 3B
Pump version:	A
Model:	A
Materials:	
Pump housing:	Cast iron EN-JL1040 ASTM A48-40 B
Impeller:	Cast iron EN-JL1030 ASTM A48-30 B
Material code:	A
Installation:	
Range of ambient temperature:	-22 .. 140 °F
Maximum operating pressure:	232 psi
Flange standard:	DIN
Pipe connection:	DN 80
Pump inlet:	DN 80
Pump outlet:	DN 80
Pressure stage:	PN 16
(@)	17 3/8 in
Flange size for motor:	FF215
Connect code:	F
Liquid:	
Pumped liquid:	Water
Liquid temperature range:	-13 .. 248 °F
Liquid temperature during operation:	68 °F
Density:	62.29 lb/ft³
Electrical data:	
Motor type:	100LB
IE Efficiency class:	IE3
Rated power - P2:	2 x 3 HP
Power (P2) required by pump:	3 HP
Main frequency:	50 Hz
Rated voltage:	3 x 380-415D V
Rated current:	4.9 A
Starting current:	600-660 %
Cos phi - power factor:	0.79-0.73
Rated speed:	1450 rpm
IE efficiency:	IE3 86,7%
Motor efficiency at full load:	86.7 %
Motor efficiency at 3/4 load:	87.7 %
Motor efficiency at 1/2 load:	87.6 %
Number of poles:	4
Enclosure class (IEC 34-5):	55 Dust/Jetting
Insulation class (IEC 85):	F
Motor protection:	NONE
Motor Number:	87270324
Others:	

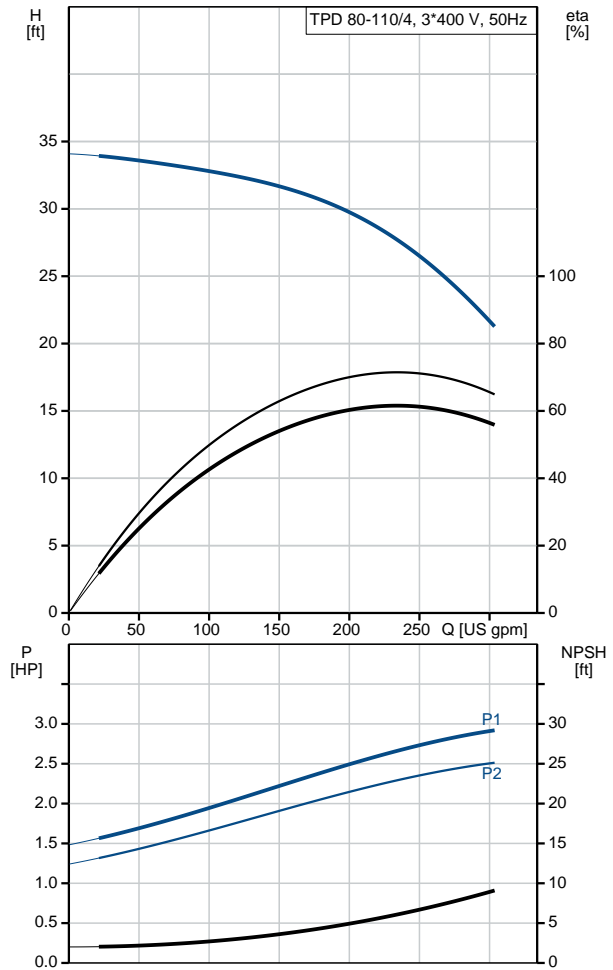



Company name:

Created by:

Phone:

Date: 10/9/2018

Description	Value
Minimum efficiency index, MEI :	0.68
ErP status:	EuP Standalone/Prod.
Net weight:	364 lb
Gross weight:	388 lb
Shipping volume:	16.2 ft ³
Country of origin:	HU
Custom tariff no.:	84137065

96108891 TPD 80-110/4 A-F-A-BQQE 50 Hz

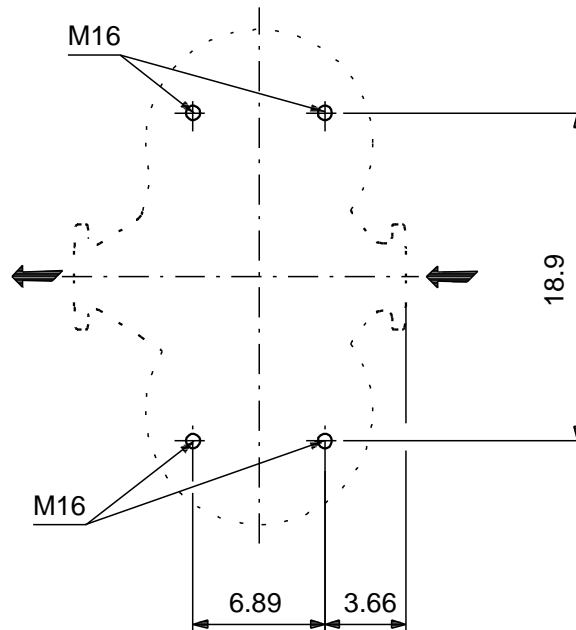
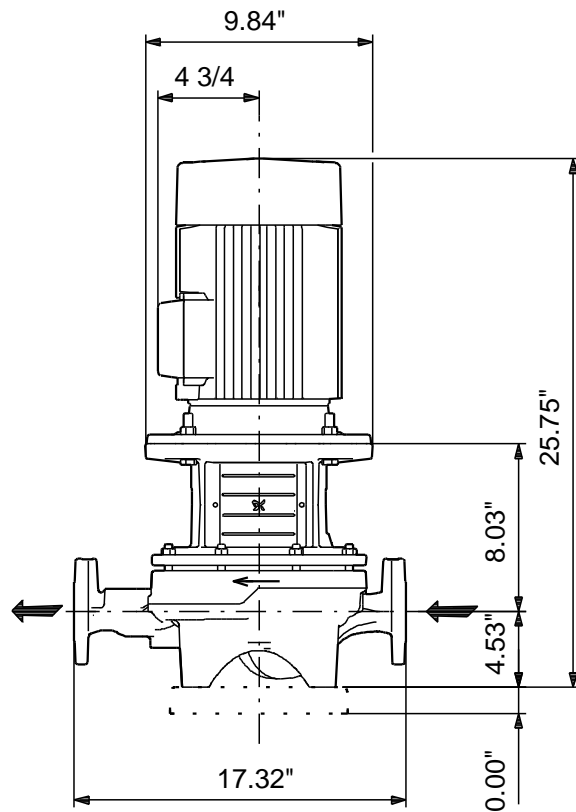
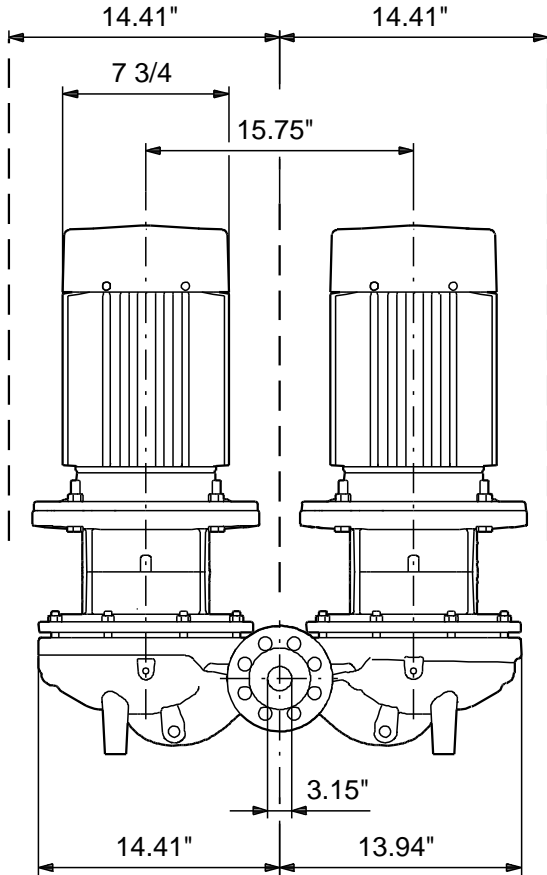

Note! All units are in [mm] unless otherwise stated.
Disclaimer: This simplified dimensional drawing does not show all details.

96108891 TPD 80-110/4 A-F-A-BQQE 50 Hz

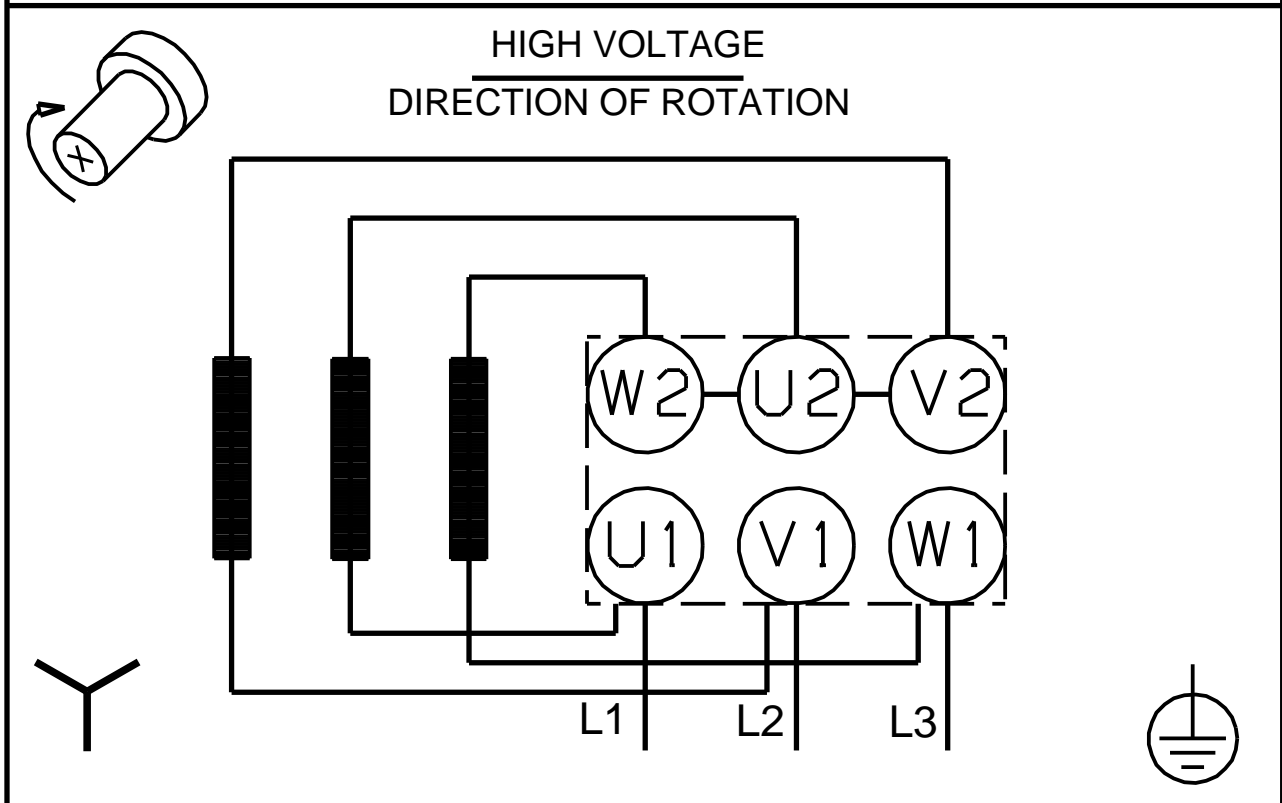

All units are [mm] unless otherwise presented.