

Position	Qty.	Description
	1	<p>TPD 80-140/2 A-F-A-BQQE</p>  <p>Product No.: 96108787</p> <p>Single-stage, close-coupled, volute twin-head pump with in-line suction and discharge ports of identical diameter. The twin-head pump is designed with two parallel power-heads. The pump is of the top-pull-out design, i.e. the power head (motor, pump head and impeller) can be removed for maintenance or service while the pump housing remains in the pipework.</p> <p>Each power head is fitted with an unbalanced rubber bellows seal. The shaft seal is according to EN 12756. Pipework connection is via PN 16 DIN flanges (EN 1092-2 and ISO 7005-2).</p> <p>Each power head is fitted with a fan-cooled asynchronous motor of identical size.</p> <p>Liquid:</p> <p>Pumped liquid: Water Liquid temperature range: -25 .. 120 °C Liquid temperature during operation: 20 °C Density: 998.2 kg/m³</p> <p>Technical:</p> <p>Rated flow: 44.9 m³/h Rated head: 10.3 m Actual impeller diameter: 105 mm Primary shaft seal: BQQE Curve tolerance: ISO9906:2012 3B</p> <p>Materials:</p> <p>Pump housing: Cast iron EN-JL1040 ASTM A48-40 B</p> <p>Impeller: Cast iron EN-JL1030 ASTM A48-30 B</p> <p>Installation:</p> <p>Range of ambient temperature: -30 .. 60 °C Maximum operating pressure: 16 bar Flange standard: DIN Pipe connection: DN 80 Pump inlet: DN 80 Pump outlet: DN 80 Pressure rating: PN 16 (@): 360 mm Flange size for motor: FF165</p> <p>Electrical data:</p> <p>Motor type: 90LC IE Efficiency class: IE3 Rated power - P2: 2 x 2.2 kW Power (P2) required by pump: 2.2 kW Mains frequency: 50 Hz</p>

Position	Qty.	Description
		<p>Rated voltage: 3 x 380-415D V</p> <p>Rated current: 4.45 A</p> <p>Starting current: 850-950 %</p> <p>Cos phi - power factor: 0.89-0.87</p> <p>Rated speed: 2890-2910 rpm</p> <p>Efficiency: IE3 85,9%</p> <p>Motor efficiency at full load: 85.9 %</p> <p>Motor efficiency at 3/4 load: 86.8 %</p> <p>Motor efficiency at 1/2 load: 86.0 %</p> <p>Number of poles: 2</p> <p>Enclosure class (IEC 34-5): 55 Dust/Jetting</p> <p>Insulation class (IEC 85): F</p> <p>Others:</p> <p>Minimum efficiency index, MEI : 0.69</p> <p>ErP status: EuP Standalone/Prod.</p> <p>Net weight: 126 kg</p> <p>Gross weight: 140 kg</p> <p>Shipping volume: 0.39 m³</p> <p>Country of origin: HU</p> <p>Custom tariff no.: 84137065</p>

96108787 TPD 80-140/2 A-F-A-BQQE 50 Hz

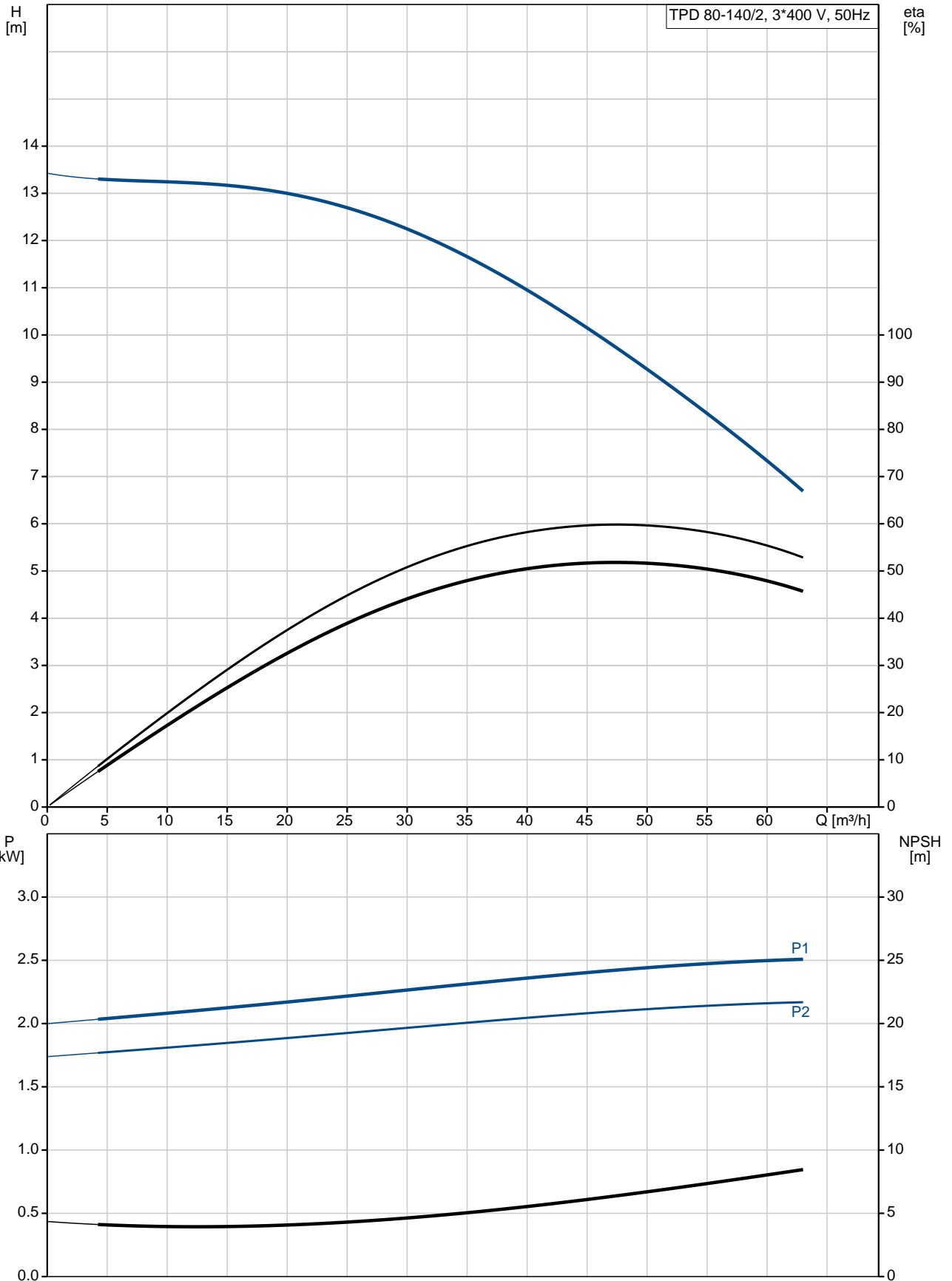

Description	Value
General information:	
Product name:	TPD 80-140/2 A-F-A-BQQE
Product No:	96108787
EAN number:	5700396977539
Price:	3.427,00 GBP
Technical:	
Rated flow:	44.9 m ³ /h
Rated head:	10.3 m
Head max:	140 dm
Actual impeller diameter:	105 mm
Primary shaft seal:	BQQE
Curve tolerance:	ISO9906:2012 3B
Pump version:	A
Model:	A
Materials:	
Pump housing:	Cast iron EN-JL1040
Impeller:	Cast iron EN-JL1030 ASTM A48-30 B
Material code:	A
Installation:	
Range of ambient temperature:	-30 .. 60 °C
Maximum operating pressure:	16 bar
Flange standard:	DIN
Pipe connection:	DN 80
Pump inlet:	DN 80
Pump outlet:	DN 80
Pressure rating:	PN 16
(@)	360 mm
Flange size for motor:	FF165
Connect code:	F
Liquid:	
Pumped liquid:	Water
Liquid temperature range:	-25 .. 120 °C
Liquid temperature during operation:	20 °C
Density:	998.2 kg/m ³
Electrical data:	
Motor type:	90LC
IE Efficiency class:	IE3
Rated power - P2:	2 x 2.2 kW
Power (P2) required by pump:	2.2 kW
Mains frequency:	50 Hz
Rated voltage:	3 x 380-415D V
Rated current:	4.45 A
Starting current:	850-950 %
Cos phi - power factor:	0.89-0.87
Rated speed:	2890-2910 rpm
Efficiency:	IE3 85,9%
Motor efficiency at full load:	85.9 %
Motor efficiency at 3/4 load:	86.8 %
Motor efficiency at 1/2 load:	86.0 %
Number of poles:	2
Enclosure class (IEC 34-5):	55 Dust/Jetting
Insulation class (IEC 85):	F
Motor protec:	NONE
Motor No:	87220294

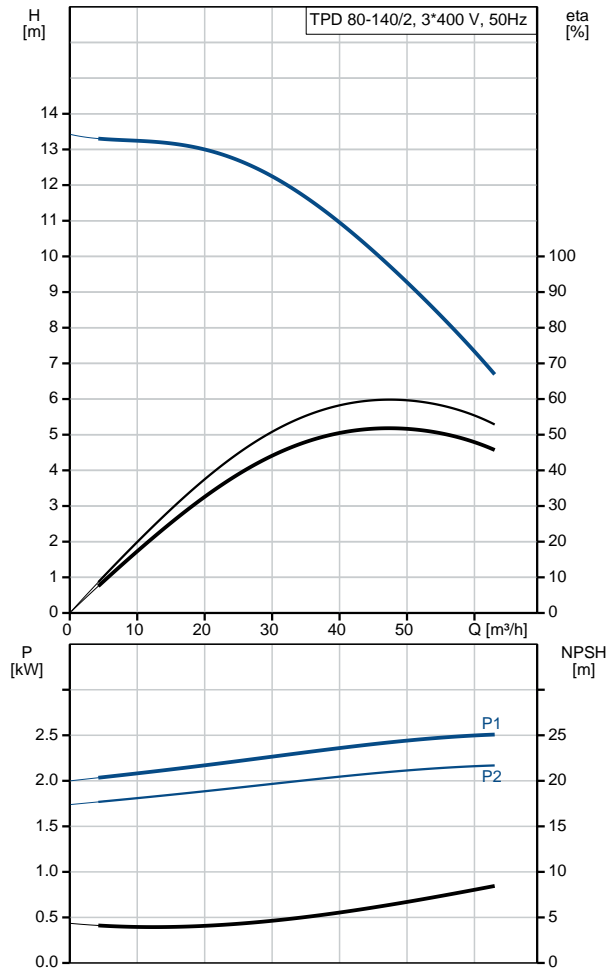



Company name:

Created by:

Phone:

Date:

11/10/2018

Description	Value
Others:	
Minimum efficiency index, MEI :	0.69
ErP status:	EuP Standalone/Prod.
Net weight:	126 kg
Gross weight:	140 kg
Shipping volume:	0.39 m ³
Country of origin:	HU
Custom tariff no.:	84137065

96108787 TPD 80-140/2 A-F-A-BQQE 50 Hz

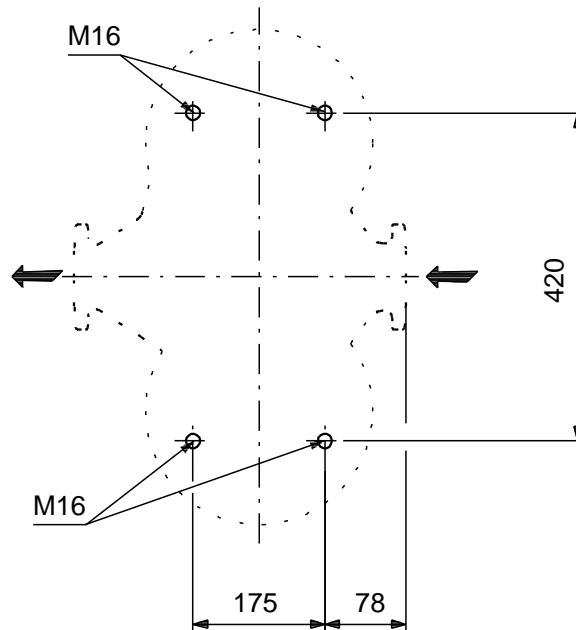
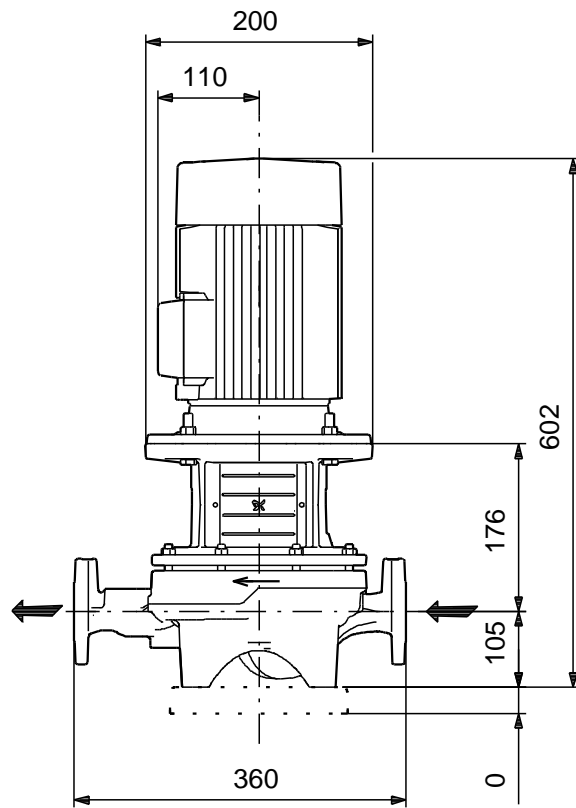
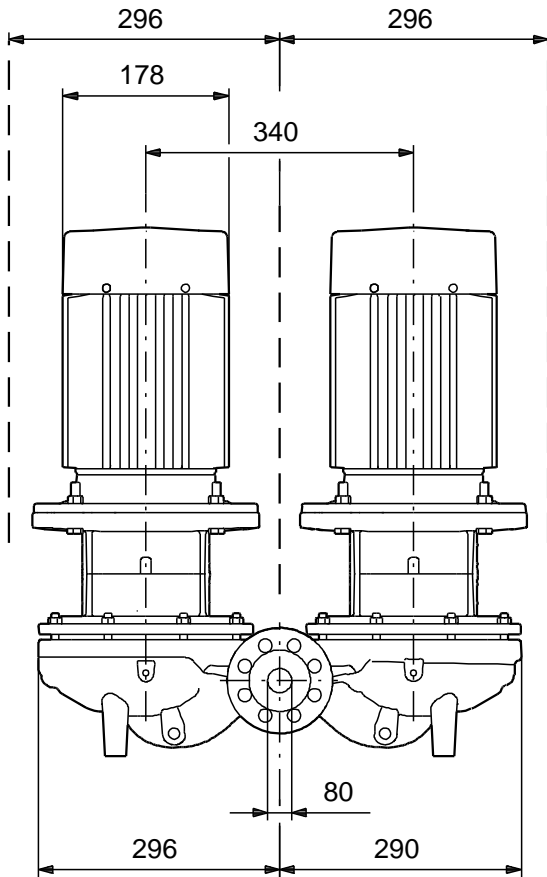

Note! All units are in [mm] unless others are stated.
Disclaimer: This simplified dimensional drawing does not show all details.

96108787 TPD 80-140/2 A-F-A-BQQE 50 Hz

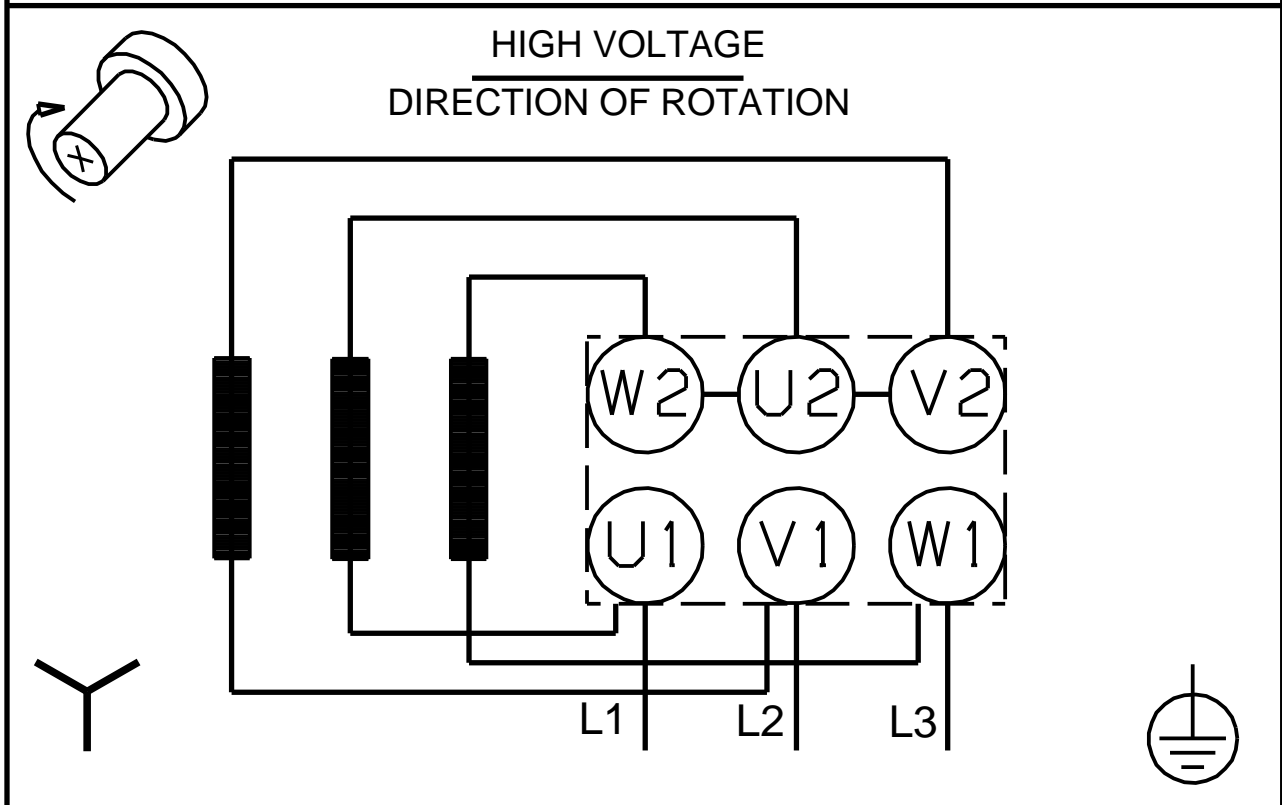
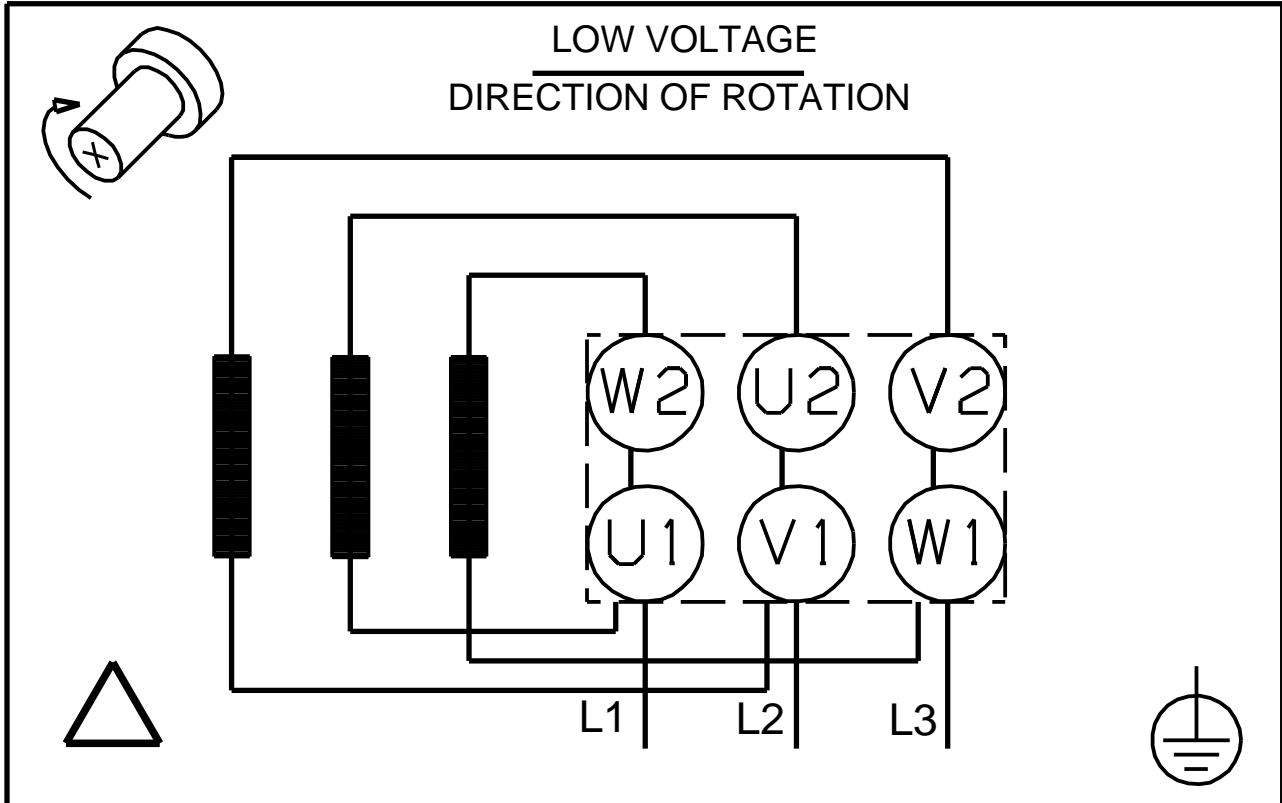

Note! All units are in [mm] unless others are stated.