

Position	Qty.	Description
	1	<p><b>TP 50-290/2 A-F-A-BQQE</b></p>  <p>Product No.: <a href="#">96087196</a></p> <p>Single-stage, close-coupled, volute pump with in-line suction and discharge ports of identical diameter. The pump is of the top-pull-out design, i.e. the power head (motor, pump head and impeller) can be removed for maintenance or service while the pump housing remains in the pipework.</p> <p>The pump is fitted with an unbalanced rubber bellows seal. The shaft seal is according to EN 12756. Pipework connection is via PN 16 DIN flanges (EN 1092-2 and ISO 7005-2).</p> <p>The pump is fitted with a fan-cooled asynchronous motor.</p> <p><b>Liquid:</b>  Pumped liquid: Water  Liquid temperature range: -25 .. 120 °C  Liquid temperature during operation: 20 °C  Density: 998.2 kg/m<sup>3</sup></p> <p><b>Technical:</b>  Speed for pump data: 2910 rpm  Rated flow: 27.4 m<sup>3</sup>/h  Rated head: 24.1 m  Actual impeller diameter: 142 mm  Primary shaft seal: BQQE  Curve tolerance: ISO9906:2012 3B</p> <p><b>Materials:</b>  Pump housing: Cast iron  EN-JL1040  ASTM A48-40 B  Impeller: Cast iron  EN-JL1030  ASTM A48-30 B</p> <p><b>Installation:</b>  Range of ambient temperature: -30 .. 60 °C  Maximum operating pressure: 16 bar  Flange standard: DIN  Pipe connection: DN 50  Pump inlet: DN 50  Pump outlet: DN 50  Pressure rating: PN 16  Port-to-port length: 340 mm  Flange size for motor: FF215</p> <p><b>Electrical data:</b>  Motor type: 100LC  IE Efficiency class: IE3  Rated power - P2: 3 kW  Power (P2) required by pump: 3 kW  Mains frequency: 50 Hz</p>

Position	Qty.	Description
		<p>Rated voltage: 3 x 380-415D V</p> <p>Rated current: 6.3 A</p> <p>Starting current: 840-920 %</p> <p>Cos phi - power factor: 0,87-0,82</p> <p>Rated speed: 2900-2920 rpm</p> <p>Efficiency: IE3 87,1%</p> <p>Motor efficiency at full load: 87.1 %</p> <p>Motor efficiency at 3/4 load: 88.0 %</p> <p>Motor efficiency at 1/2 load: 87.7 %</p> <p>Number of poles: 2</p> <p>Enclosure class (IEC 34-5): 55 Dust/Jetting</p> <p>Insulation class (IEC 85): F</p> <p><b>Others:</b></p> <p>Minimum efficiency index, MEI : 0.70</p> <p>ErP status: EuP Standalone/Prod.</p> <p>Net weight: 61 kg</p> <p>Gross weight: 78 kg</p> <p>Shipping volume: 0.18 m<sup>3</sup></p>

## 96087196 TP 50-290/2 50 Hz

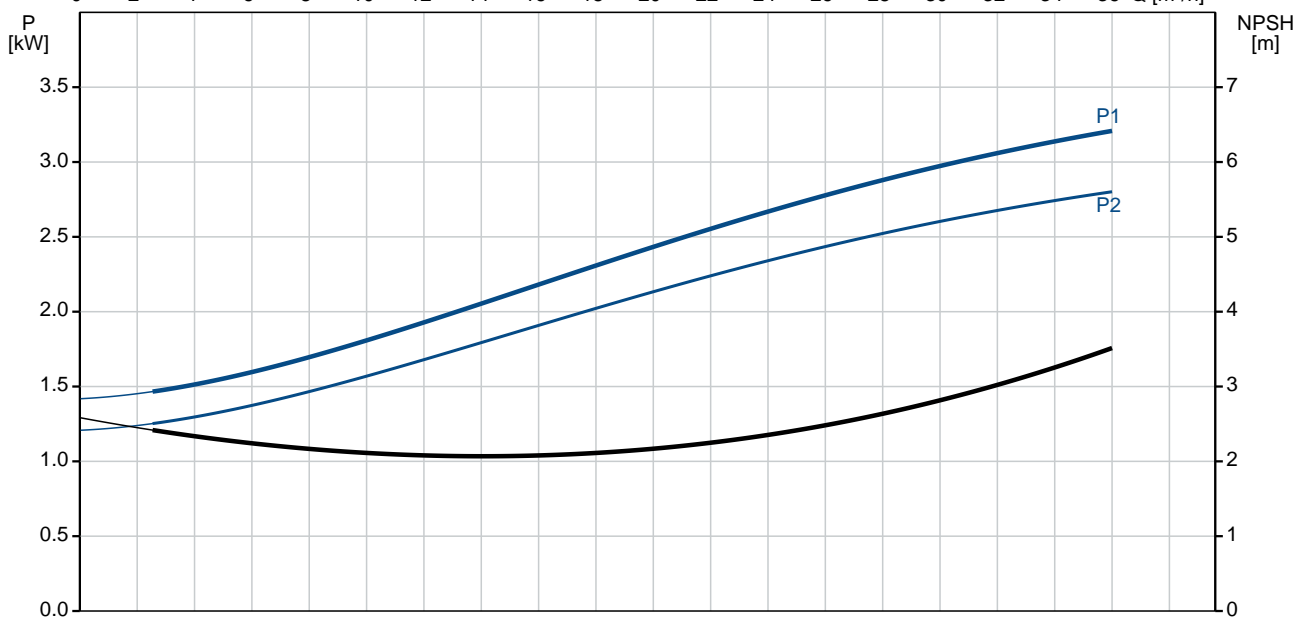
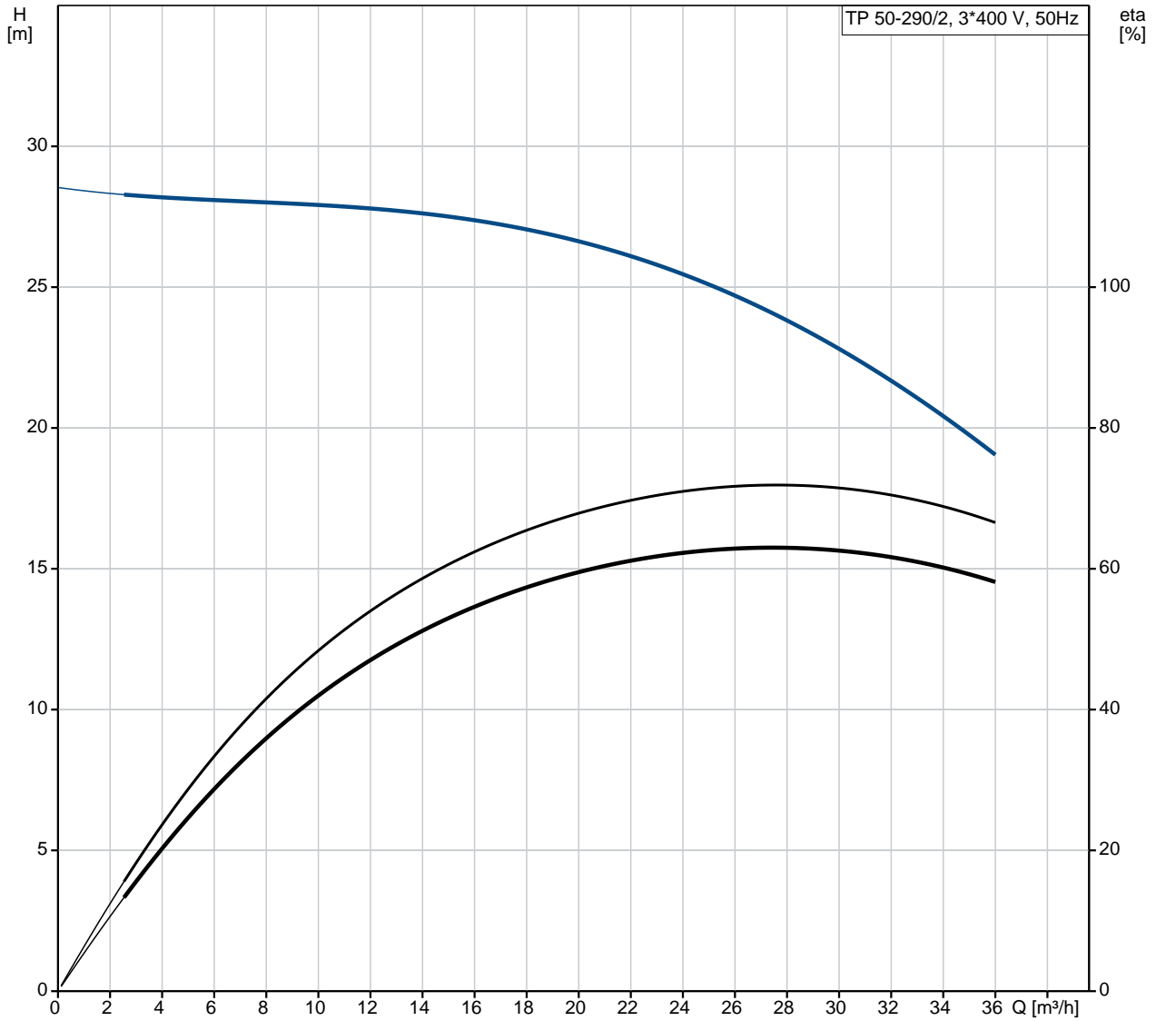

Description	Value
<b>General information:</b>	
Product name:	TP 50-290/2 A-F-A-BQQE
Product No:	96087196
EAN number:	5700395311624
<b>Technical:</b>	
Speed for pump data:	2910 rpm
Rated flow:	27.4 m <sup>3</sup> /h
Rated head:	24.1 m
Head max:	290 dm
Actual impeller diameter:	142 mm
Primary shaft seal:	BQQE
Curve tolerance:	ISO9906:2012 3B
Pump version:	A
Model:	A
<b>Materials:</b>	
Pump housing:	Cast iron EN-JL1040 ASTM A48-40 B
Impeller:	Cast iron EN-JL1030 ASTM A48-30 B
Material code:	A
<b>Installation:</b>	
Range of ambient temperature:	-30 .. 60 °C
Maximum operating pressure:	16 bar
Flange standard:	DIN
Connect code:	F
Pipe connection:	DN 50
Pump inlet:	DN 50
Pump outlet:	DN 50
Pressure rating:	PN 16
Port-to-port length:	340 mm
Flange size for motor:	FF215
<b>Liquid:</b>	
Pumped liquid:	Water
Liquid temperature range:	-25 .. 120 °C
Liquid temperature during operation:	20 °C
Density:	998.2 kg/m <sup>3</sup>
<b>Electrical data:</b>	
Motor type:	100LC
IE Efficiency class:	IE3
Rated power - P2:	3 kW
Power (P2) required by pump:	3 kW
Mains frequency:	50 Hz
Rated voltage:	3 x 380-415D V
Rated current:	6.3 A
Starting current:	840-920 %
Cos phi - power factor:	0,87-0,82
Rated speed:	2900-2920 rpm
Efficiency:	IE3 87,1%
Motor efficiency at full load:	87.1 %
Motor efficiency at 3/4 load:	88.0 %
Motor efficiency at 1/2 load:	87.7 %
Number of poles:	2

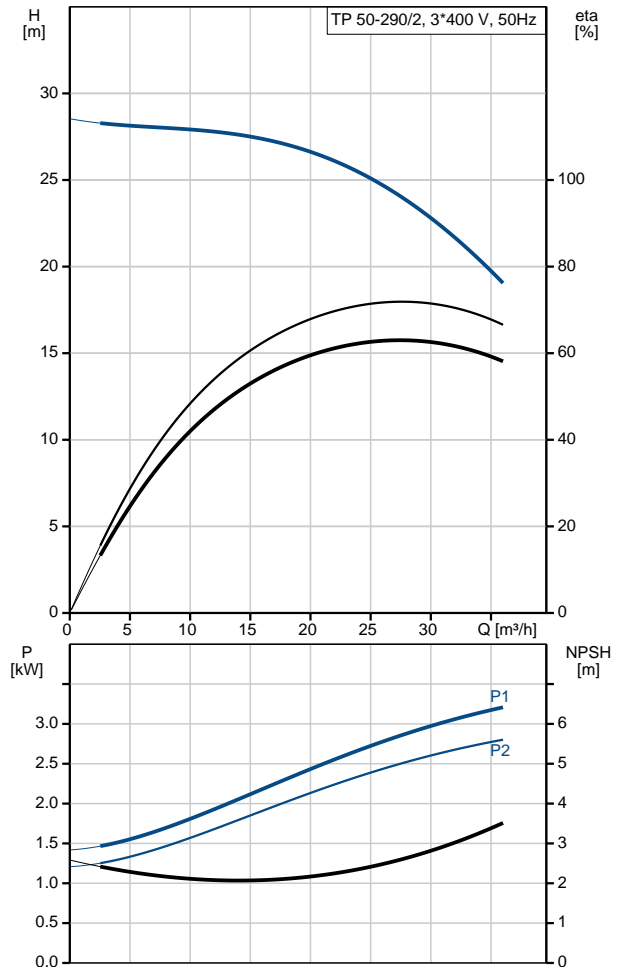



Company name:

Created by:

Phone:

Date:

26/01/2018

Description	Value
Enclosure class (IEC 34-5):	55 Dust/Jetting
Insulation class (IEC 85):	F
Motor protec:	PTC
Motor No:	87272297
<b>Others:</b>	
Minimum efficiency index, MEI :	0.70
ErP status:	EuP Standalone/Prod.
Net weight:	61 kg
Gross weight:	78 kg
Shipping volume:	0.18 m <sup>3</sup>

## 96087196 TP 50-290/2 50 Hz

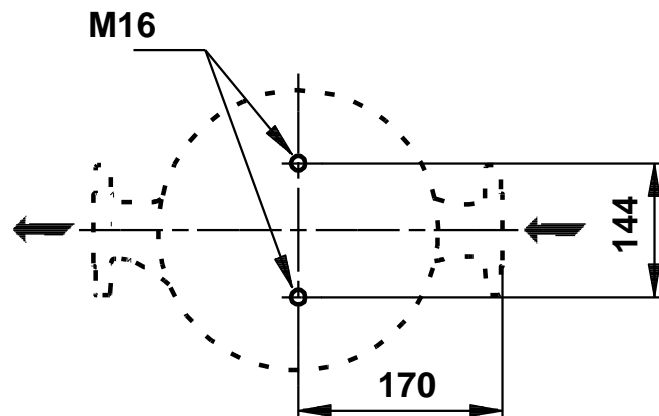
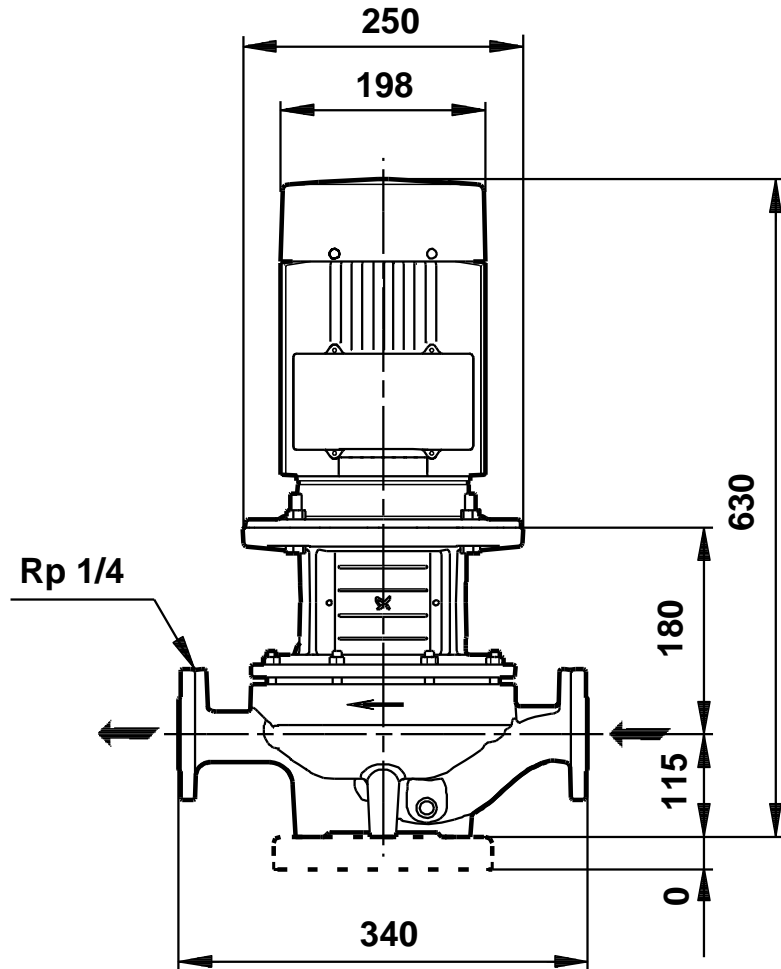
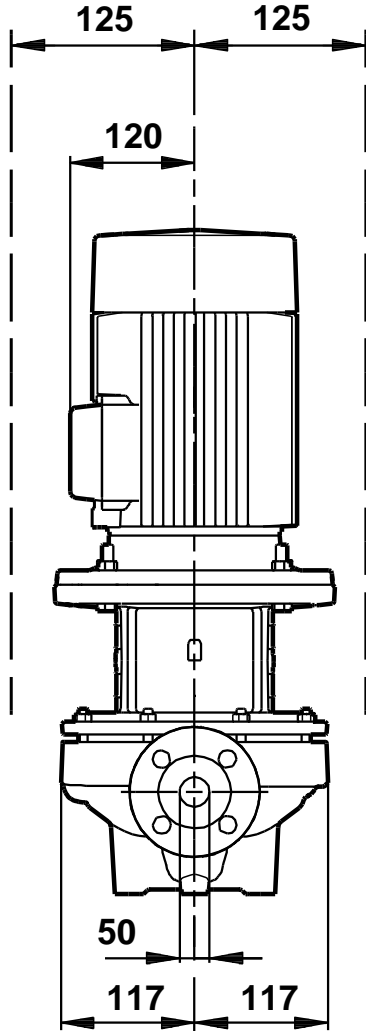

Note! All units are in [mm] unless others are stated.  
Disclaimer: This simplified dimensional drawing does not show all details.

## 96087196 TP 50-290/2 50 Hz

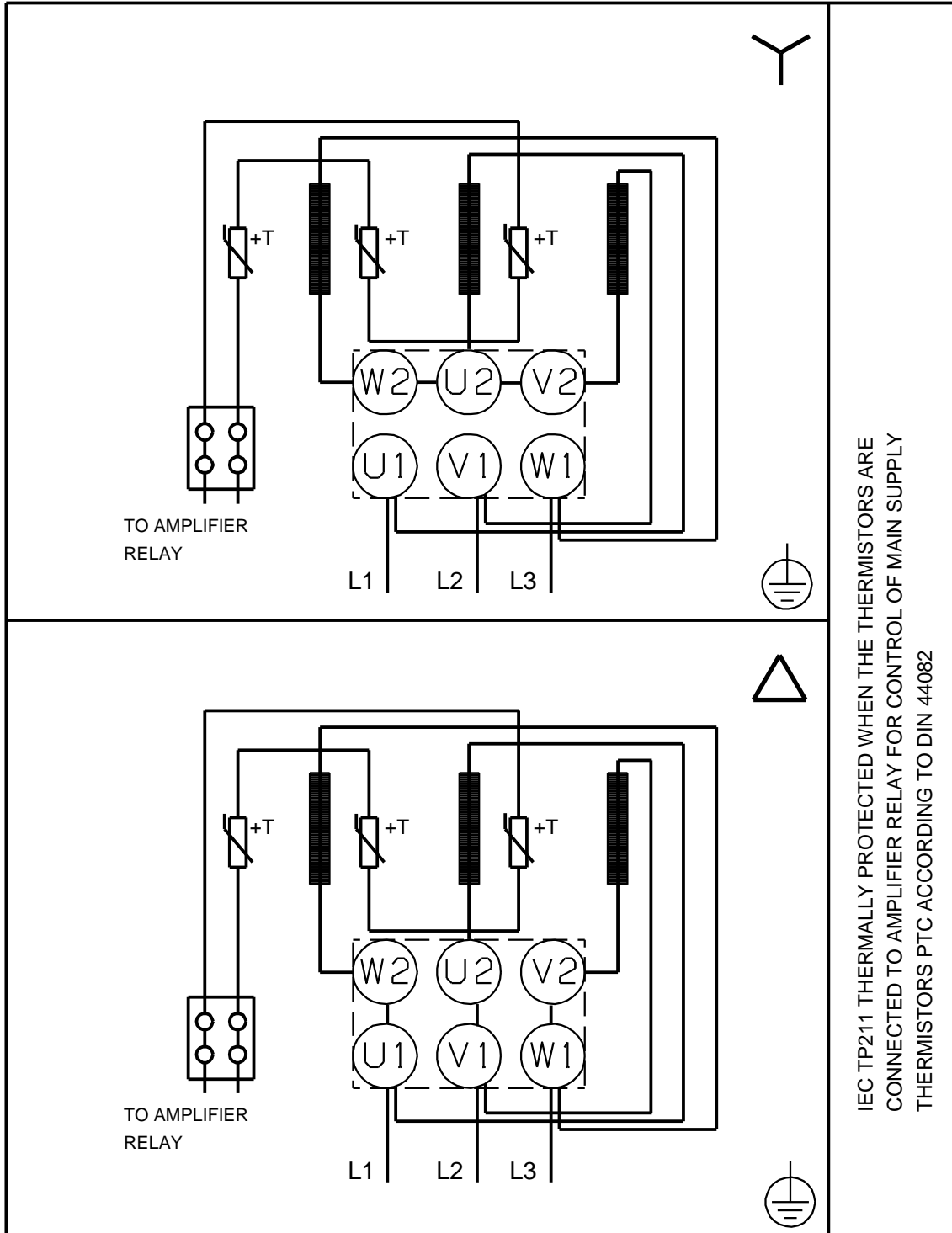

IEC TP211 THERMALLY PROTECTED WHEN THE THERMISTORS ARE  
CONNECTED TO AMPLIFIER RELAY FOR CONTROL OF MAIN SUPPLY  
THERMISTORS PTC ACCORDING TO DIN 44082

Note! All units are in [mm] unless others are stated.