

Qty. Description

1 SE1.50.80.40.2.51D.B



Note! Product picture may differ from actual product

Product No.: [96047997](#)

Non-self-priming, single-stage, centrifugal pump designed for handling wastewater, process water and unscreened raw sewage.

The pump is designed for intermittent and continuous operation. The liquidless and maintenance free cooling system ensures that the pump can be used for submerged or dry installation. The revolutionary S-tube® impeller provides free spherical passage of solids up to 50 mm and is suitable for wastewater with a dry matter content of up to 3 %.

A unique stainless-steel clamp assembling system enables quick and easy disassembly of the pump from the motor unit for service and inspection. No special tools are required. Pipework connection is via a DIN flange.

Controls:

Moisture sensor: without moisture sensors
 Water-in-oil sensor: without water-in-oil sensor
 Temp. sensor: N

Liquid:

Pumped liquid: Any Newtonian liquid
 Liquid temperature range: 0 .. 40 °C
 Density: 998.2 kg/m³

Technical:

Type of impeller: S-TUBE
 Maximum particle size: 50 mm
 Primary shaft seal: SIC/SIC
 Secondary shaft seal: CARBON/CERAMICS
 Max. hydraulic efficiency: 68 %
 Approvals on nameplate: EN12050-2
 Curve tolerance: ISO9906:2012 3B2

Materials:

Pump housing: EN 1561 EN-GJL-250
 Impeller: Cast iron

Installation:

Maximum operating pressure: 6 bar
 Flange standard: DIN
 Pump outlet: DN 80
 Pressure rating: PN 10
 Maximum installation depth: 20 m

Electrical data:

Power input - P1: 4.8 kW
 Rated power - P2: 4 kW
 Mains frequency: 50 Hz
 Rated voltage: 3 x 380-415 V
 Voltage tolerance: +6/-10 %

Qty.	Description																																																										
	<table> <tr><td>Max starts per. hour:</td><td>20</td></tr> <tr><td>Rated current:</td><td>8.7-8.5 A</td></tr> <tr><td>Rated current at 3/4 load:</td><td>6.7 A</td></tr> <tr><td>Rated current at 1/2 load:</td><td>5.4 A</td></tr> <tr><td>Starting current:</td><td>71 A</td></tr> <tr><td>Rated current at no load:</td><td>3.9 A</td></tr> <tr><td>Cos phi - power factor:</td><td>0.84</td></tr> <tr><td>Cos phi - p.f. at no load:</td><td>0.15</td></tr> <tr><td>Cos phi - p.f. at 3/4 load:</td><td>0.78</td></tr> <tr><td>Cos phi - p.f. at 1/2 load:</td><td>0.68</td></tr> <tr><td>Rated speed:</td><td>2925 rpm</td></tr> <tr><td>Locked-rotor torque:</td><td>40 Nm</td></tr> <tr><td>Breakdown torque:</td><td>54 Nm</td></tr> <tr><td>Moment of inertia:</td><td>0.019 kg m²</td></tr> <tr><td>Motor efficiency at full load:</td><td>83.3 %</td></tr> <tr><td>Motor efficiency at 3/4 load:</td><td>82.4 %</td></tr> <tr><td>Motor efficiency at 1/2 load:</td><td>79.2 %</td></tr> <tr><td>Number of poles:</td><td>2</td></tr> <tr><td>Start. method:</td><td>star/delta</td></tr> <tr><td>Enclosure class (IEC 34-5):</td><td>IP68</td></tr> <tr><td>Insulation class (IEC 85):</td><td>F</td></tr> <tr><td>Explosion proof:</td><td>no</td></tr> <tr><td>Length of cable:</td><td>10 m</td></tr> <tr><td>Cable type:</td><td>LYNIFLEX</td></tr> <tr><td>Type of cable plug:</td><td>NO PLUG</td></tr> <tr><td colspan="2">Others:</td></tr> <tr><td>Net weight:</td><td>124 kg</td></tr> <tr><td>Country of origin:</td><td>HU</td></tr> <tr><td>Custom tariff no.:</td><td>84137021</td></tr> </table>	Max starts per. hour:	20	Rated current:	8.7-8.5 A	Rated current at 3/4 load:	6.7 A	Rated current at 1/2 load:	5.4 A	Starting current:	71 A	Rated current at no load:	3.9 A	Cos phi - power factor:	0.84	Cos phi - p.f. at no load:	0.15	Cos phi - p.f. at 3/4 load:	0.78	Cos phi - p.f. at 1/2 load:	0.68	Rated speed:	2925 rpm	Locked-rotor torque:	40 Nm	Breakdown torque:	54 Nm	Moment of inertia:	0.019 kg m ²	Motor efficiency at full load:	83.3 %	Motor efficiency at 3/4 load:	82.4 %	Motor efficiency at 1/2 load:	79.2 %	Number of poles:	2	Start. method:	star/delta	Enclosure class (IEC 34-5):	IP68	Insulation class (IEC 85):	F	Explosion proof:	no	Length of cable:	10 m	Cable type:	LYNIFLEX	Type of cable plug:	NO PLUG	Others:		Net weight:	124 kg	Country of origin:	HU	Custom tariff no.:	84137021
Max starts per. hour:	20																																																										
Rated current:	8.7-8.5 A																																																										
Rated current at 3/4 load:	6.7 A																																																										
Rated current at 1/2 load:	5.4 A																																																										
Starting current:	71 A																																																										
Rated current at no load:	3.9 A																																																										
Cos phi - power factor:	0.84																																																										
Cos phi - p.f. at no load:	0.15																																																										
Cos phi - p.f. at 3/4 load:	0.78																																																										
Cos phi - p.f. at 1/2 load:	0.68																																																										
Rated speed:	2925 rpm																																																										
Locked-rotor torque:	40 Nm																																																										
Breakdown torque:	54 Nm																																																										
Moment of inertia:	0.019 kg m ²																																																										
Motor efficiency at full load:	83.3 %																																																										
Motor efficiency at 3/4 load:	82.4 %																																																										
Motor efficiency at 1/2 load:	79.2 %																																																										
Number of poles:	2																																																										
Start. method:	star/delta																																																										
Enclosure class (IEC 34-5):	IP68																																																										
Insulation class (IEC 85):	F																																																										
Explosion proof:	no																																																										
Length of cable:	10 m																																																										
Cable type:	LYNIFLEX																																																										
Type of cable plug:	NO PLUG																																																										
Others:																																																											
Net weight:	124 kg																																																										
Country of origin:	HU																																																										
Custom tariff no.:	84137021																																																										

96047997 SE1.50.80.40.2.51D.B 50 Hz

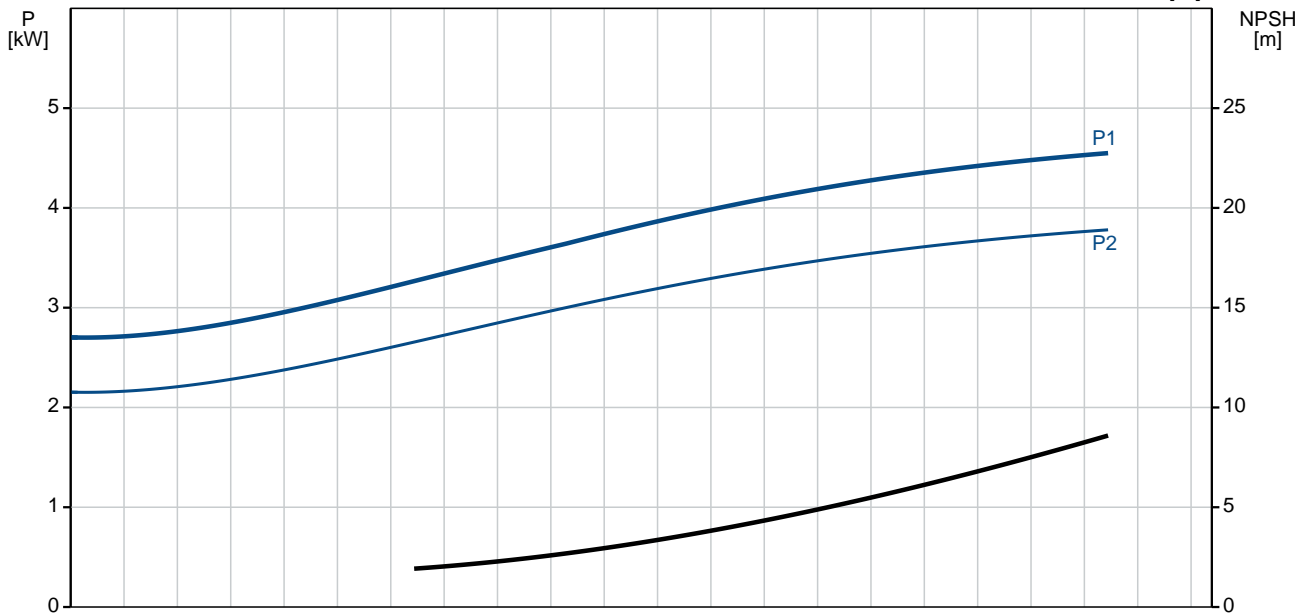
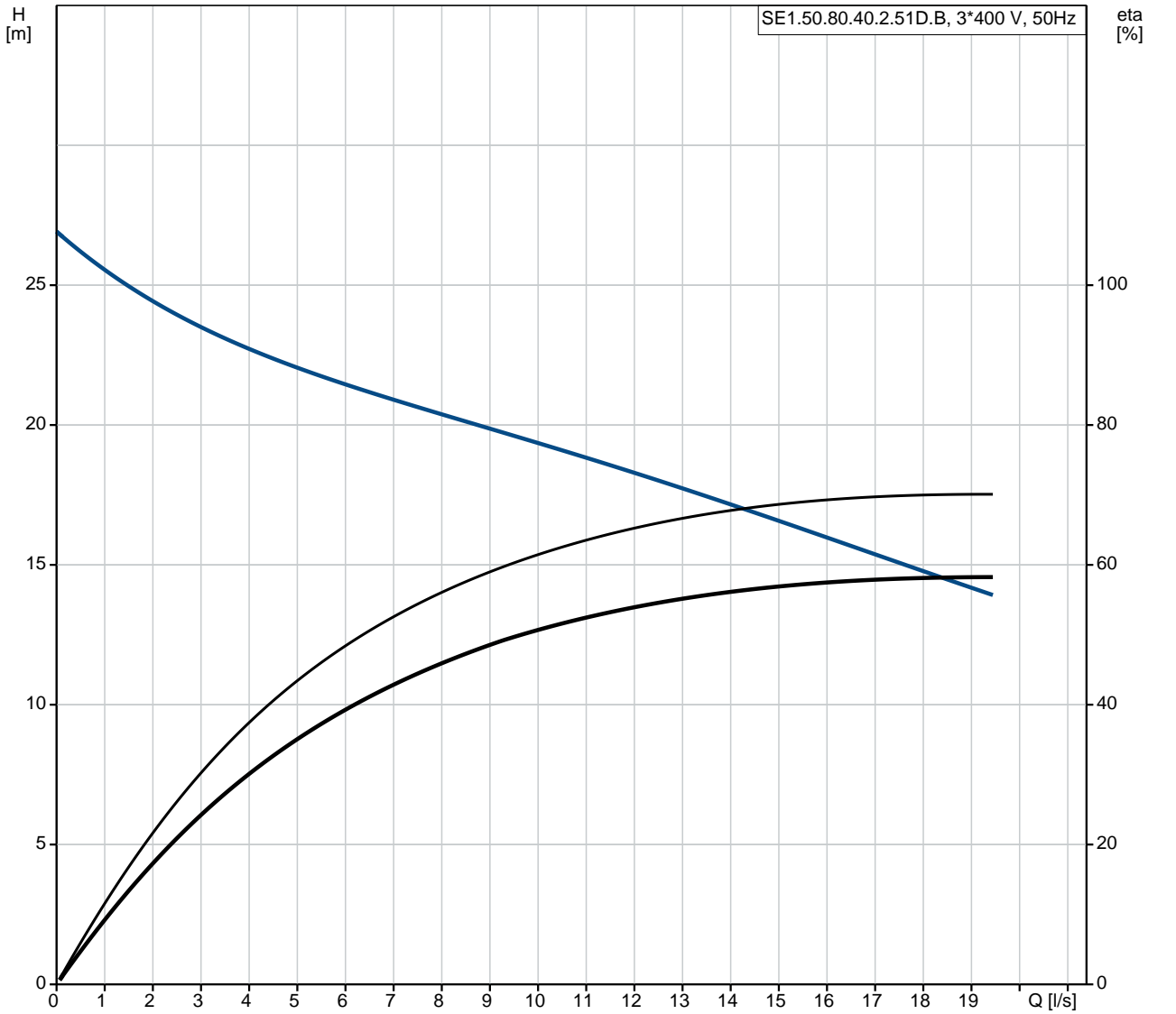

Description	Value
General information:	
Product name:	SE1.50.80.40.2.51D.B
Product No:	96047997
EAN number:	5700395061550
	5700395061550
Price:	3.210,00 GBP
Technical:	
Max flow:	19.4 l/s
Head max:	26.9 m
Type of impeller:	S-TUBE
Maximum particle size:	50 mm
Primary shaft seal:	SIC/SIC
Secondary shaft seal:	CARBON/CERAMICS
Max. hydraulic efficiency:	68 %
Approvals on nameplate:	EN12050-2
Curve tolerance:	ISO9906:2012 3B2
Cooling jacket:	with cooling jacket
Materials:	
Pump housing:	EN 1561 EN-GJL-250
Impeller:	Cast iron
Installation:	
Maximum operating pressure:	6 bar
Flange standard:	DIN
Pump outlet:	DN 80
Pressure rating:	PN 10
Maximum installation depth:	20 m
Inst dry/wet:	DRY/SUBMERGED
Installation:	horizontal or vertical
Liquid:	
Pumped liquid:	Any Newtonian liquid
Liquid temperature range:	0 .. 40 °C
Density:	998.2 kg/m ³
Electrical data:	
Power input - P1:	4.8 kW
Rated power - P2:	4 kW
Mains frequency:	50 Hz
Rated voltage:	3 x 380-415 V
Voltage tolerance:	+6/-10 %
Max starts per. hour:	20
Rated current:	8.7-8.5 A
Rated current at 3/4 load:	6.7 A
Rated current at 1/2 load:	5.4 A
Starting current:	71 A
Rated current at no load:	3.9 A
Cos phi - power factor:	0.84
Cos phi - p.f. at no load:	0.15
Cos phi - p.f. at 3/4 load:	0.78
Cos phi - p.f. at 1/2 load:	0.68
Rated speed:	2925 rpm
Locked-rotor torque:	40 Nm
Breakdown torque:	54 Nm
Moment of inertia:	0.019 kg m ²
Motor efficiency at full load:	83.3 %
Motor efficiency at 3/4 load:	82.4 %
Motor efficiency at 1/2 load:	79.2 %
Number of poles:	2
Start. method:	star/delta
Enclosure class (IEC 34-5):	IP68

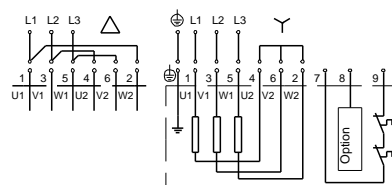
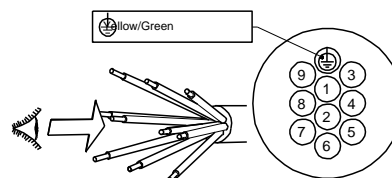
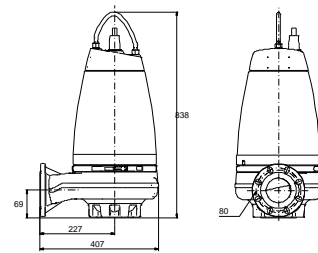
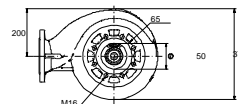
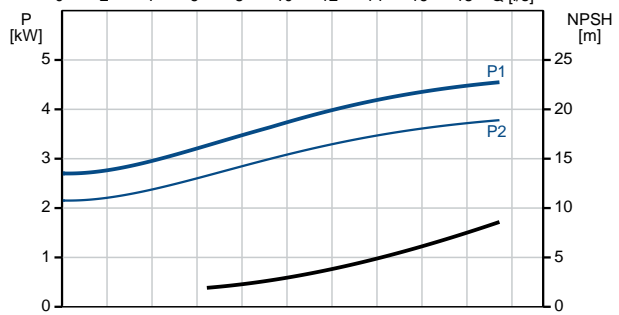
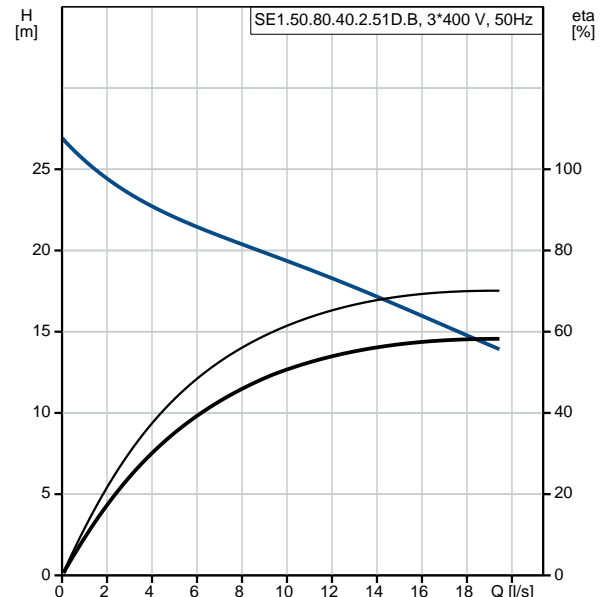



Company name:

Created by:

Phone:

Date:

21/01/2020

Description	Value
Insulation class (IEC 85):	F
Explosion proof:	no
Motor protec:	THERMAL SWITCH
Thermal protec:	internal
Length of cable:	10 m
Cable type:	LYNIFLEX
Type of cable plug:	NO PLUG
Controls:	
Control box:	not included
Moisture sensor:	without moisture sensors
Water-in-oil sensor:	without water-in-oil sensor
Temp. sensor:	N
Others:	
Net weight:	124 kg
Country of origin:	HU
Custom tariff no.:	84137021

96047997 SE1.50.80.40.2.51D.B 50 Hz

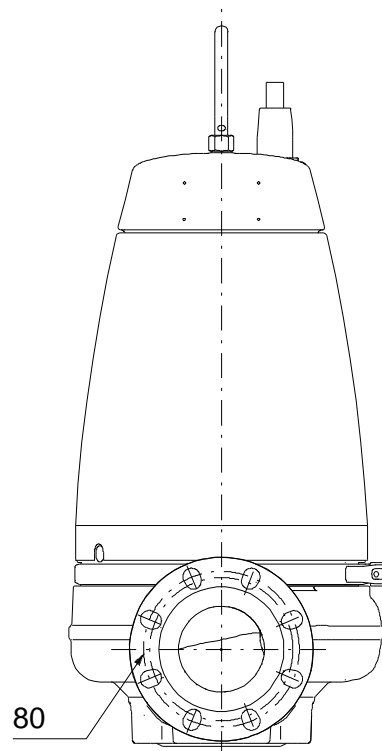
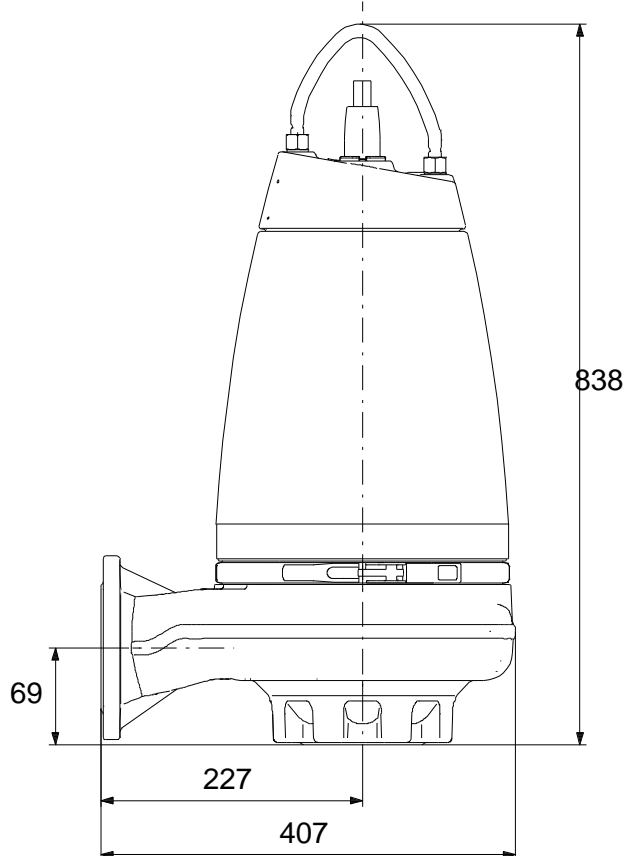
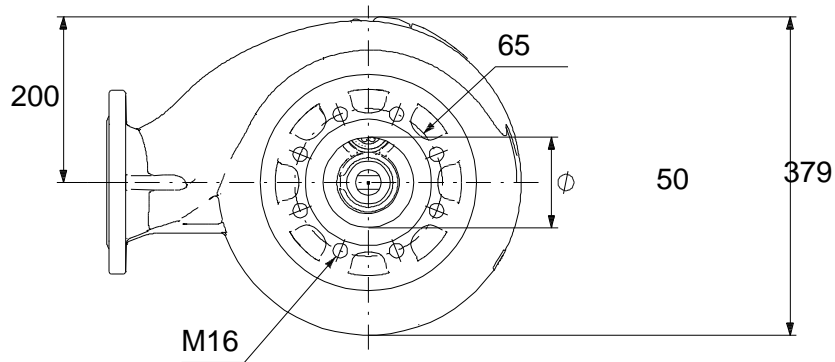

Note! All units are in [mm] unless others are stated.
Disclaimer: This simplified dimensional drawing does not show all details.

96047997 SE1.50.80.40.2.51D.B 50 Hz

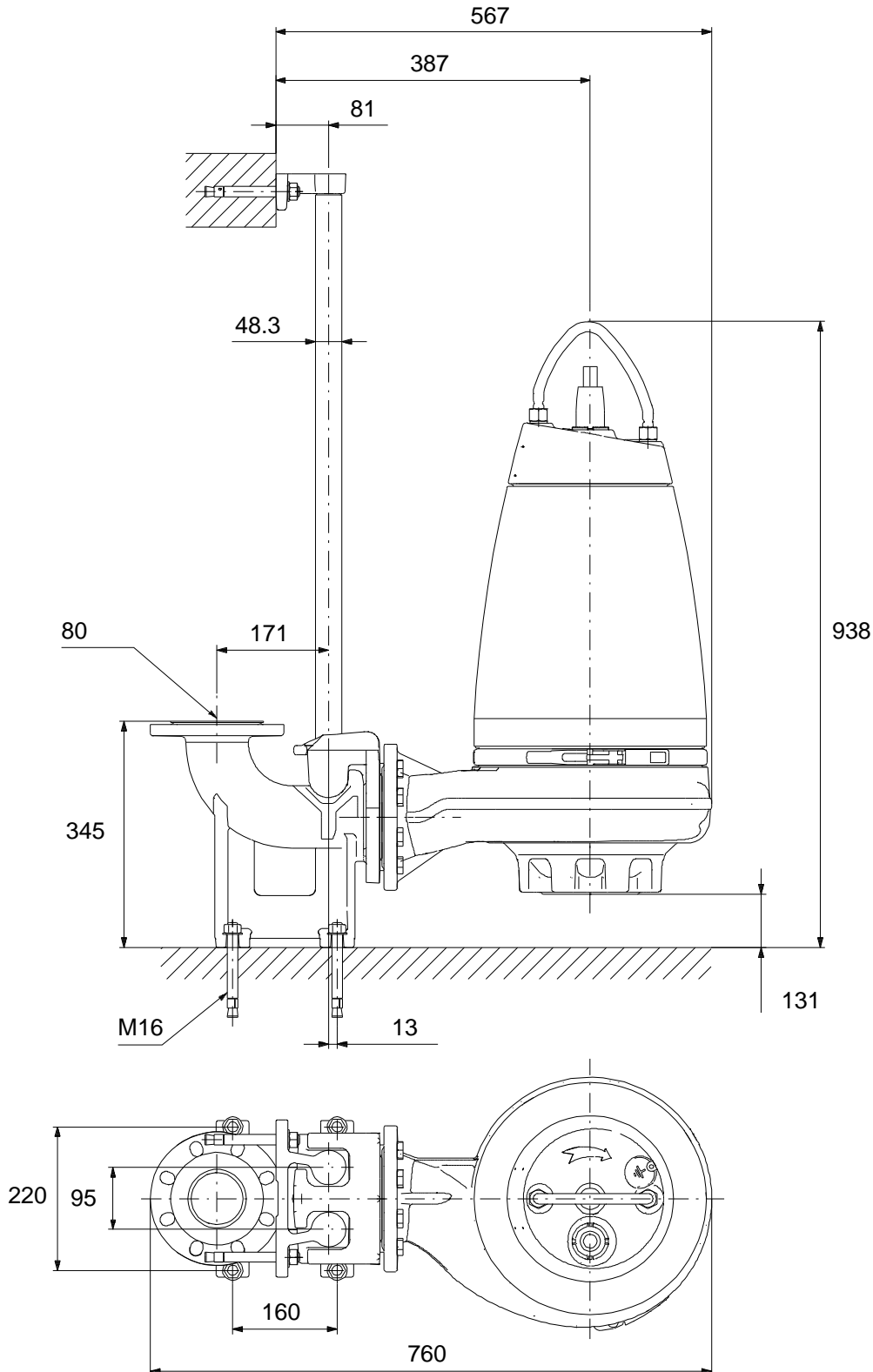

Note! All units are in [mm] unless others are stated.
Disclaimer: This simplified dimensional drawing does not show all details.

96047997 SE1.50.80.40.2.51D.B 50 Hz

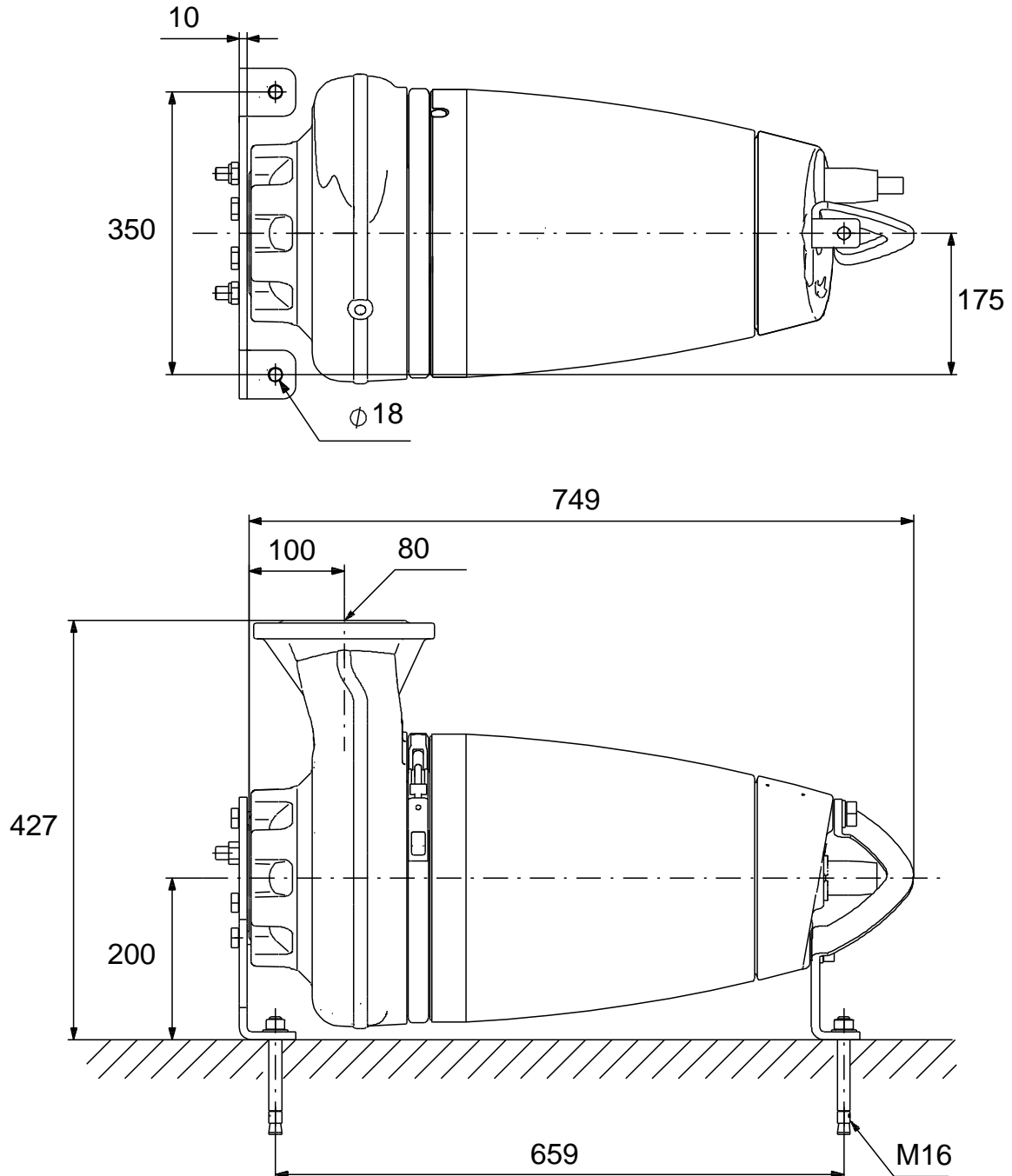

Note! All units are in [mm] unless others are stated.
Disclaimer: This simplified dimensional drawing does not show all details.

96047997 SE1.50.80.40.2.51D.B 50 Hz

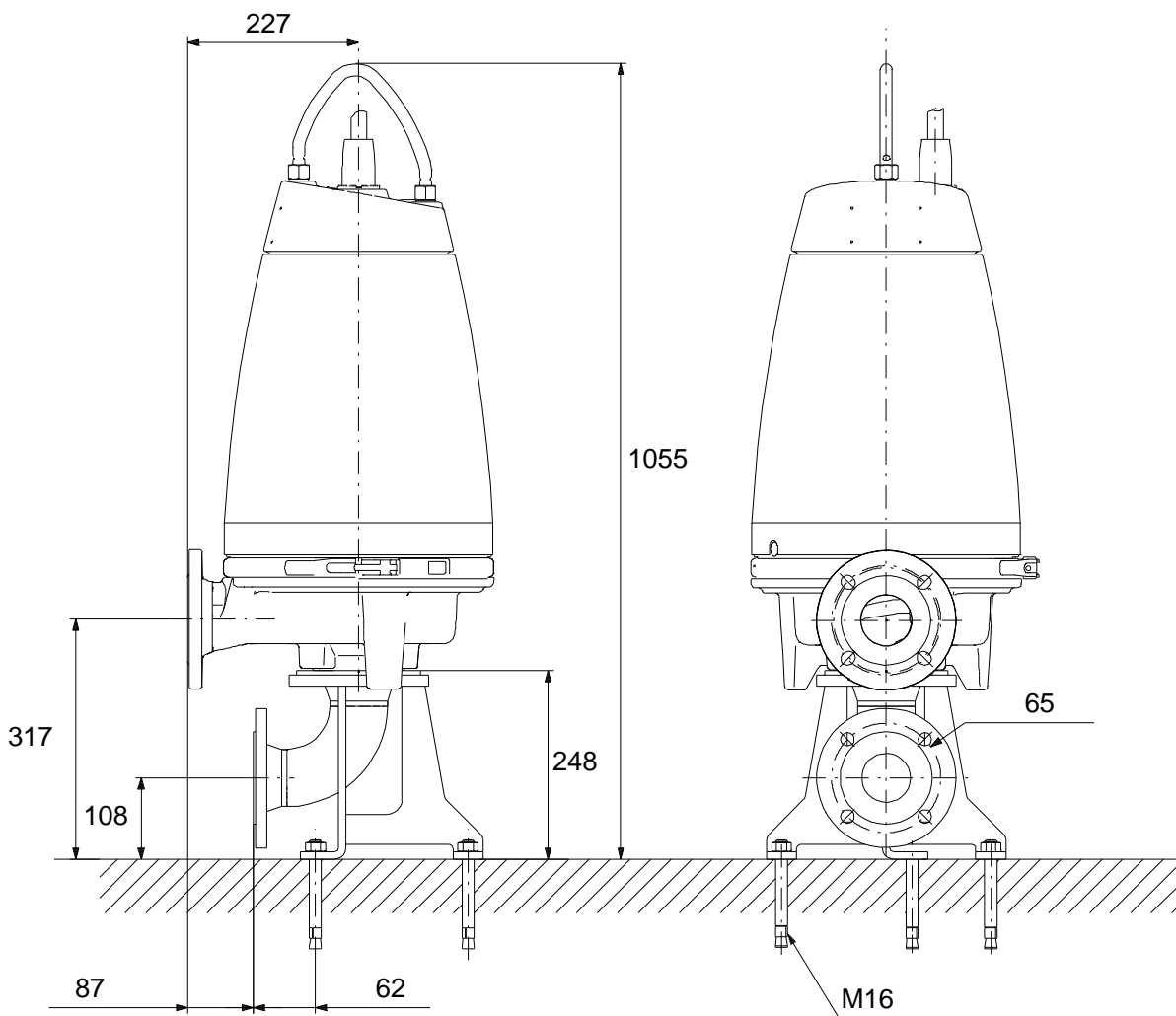
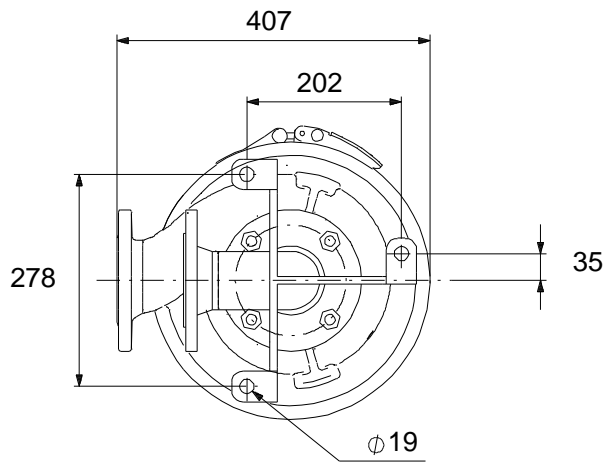

Note! All units are in [mm] unless others are stated.
Disclaimer: This simplified dimensional drawing does not show all details.

96047997 SE1.50.80.40.2.51D.B 50 Hz

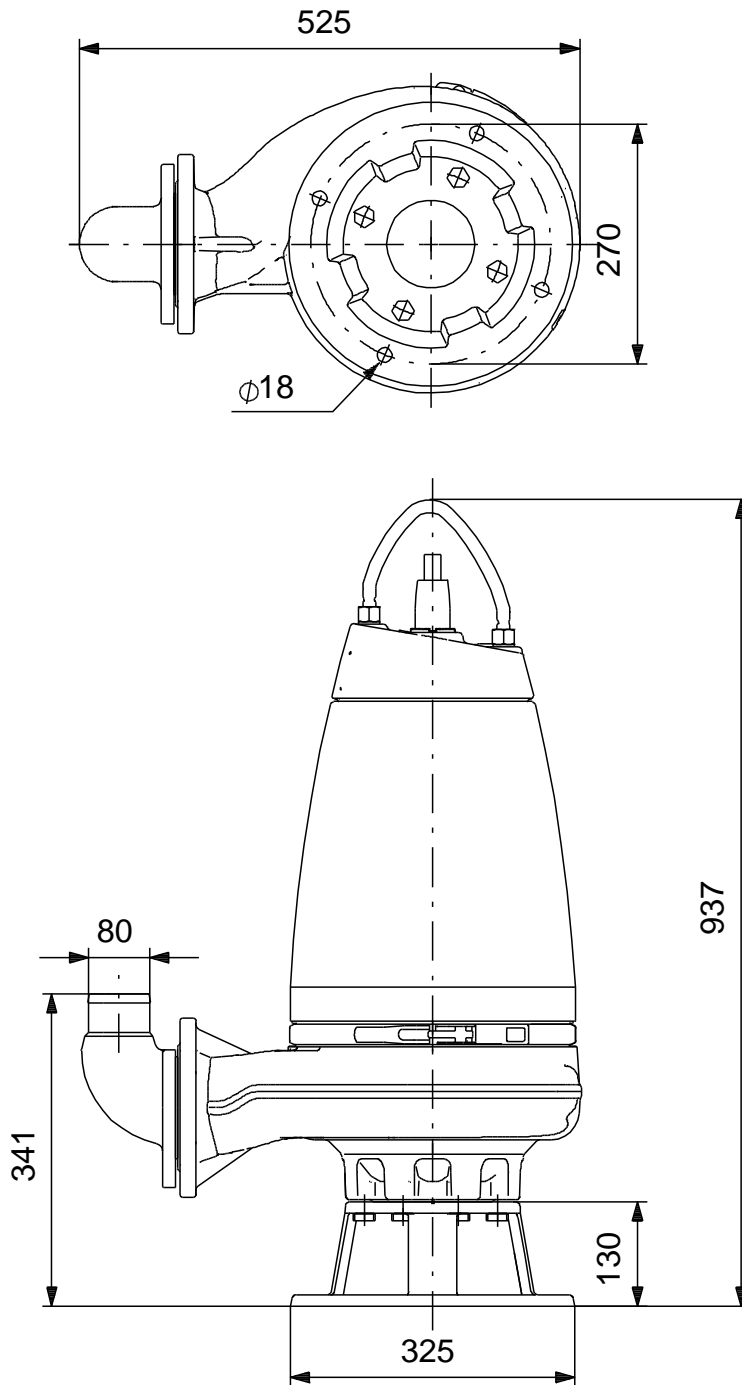

Note! All units are in [mm] unless others are stated.
Disclaimer: This simplified dimensional drawing does not show all details.