

Qty. Description

1 SE1.80.80.55.4.51D.B



Note! Product picture may differ from actual product

Product No.: [96047613](#)

Non-self-priming, single-stage, centrifugal pump designed for handling wastewater, process water and unscreened raw sewage.

The pump is designed for intermittent and continuous operation. The liquidless and maintenance free cooling system ensures that the pump can be used for submerged or dry installation. The revolutionary S-tube® impeller provides free spherical passage of solids up to 80 mm and is suitable for wastewater with a dry matter content of up to 3 %.

A unique stainless-steel clamp assembling system enables quick and easy disassembly of the pump from the motor unit for service and inspection. No special tools are required. Pipework connection is via a DIN flange.

Controls:

Moisture sensor: without moisture sensors
 Water-in-oil sensor: without water-in-oil sensor
 Temp. sensor: N

Liquid:

Pumped liquid: Any Newtonian liquid
 Liquid temperature range: 0 .. 40 °C
 Density: 998.2 kg/m³

Technical:

Type of impeller: S-TUBE
 Maximum particle size: 80 mm
 Primary shaft seal: SIC/SIC
 Secondary shaft seal: CARBON/CERAMICS
 Max. hydraulic efficiency: 68 %
 Approvals on nameplate: EN12050-1
 Curve tolerance: ISO9906:2012 3B2

Materials:

Pump housing: EN 1561 EN-GJL-250
 Impeller: Cast iron

Installation:

Maximum operating pressure: 6 bar
 Flange standard: DIN
 Pump outlet: DN 80
 Pressure rating: PN 10
 Maximum installation depth: 20 m

Electrical data:

Power input - P1: 6.5 kW
 Rated power - P2: 5.5 kW
 Mains frequency: 50 Hz
 Rated voltage: 3 x 380-415 V
 Voltage tolerance: +6/-10 %

| Qty. | Description | | | | | | | | | | | | | | | | | | | | | | | | | | | | | | | | | | | | | | | | | | | | | | | | | | | | | | | | | | |
|--------------------------------|---|-----------------------|----|----------------|-------------|----------------------------|------|----------------------------|-------|-------------------|------|---------------------------|-------|-------------------------|------|----------------------------|-----|-----------------------------|------|-----------------------------|------|--------------|----------|----------------------|-------|-------------------|--------|--------------------|--------------------------|--------------------------------|--------|-------------------------------|--------|-------------------------------|------|------------------|---|----------------|------------|-----------------------------|------|----------------------------|---|------------------|----|------------------|------|-------------|----------|---------------------|---------|----------------|--|-------------|--------|--------------------|----|--------------------|----------|
| | <table> <tr> <td>Max starts per. hour:</td> <td>20</td> </tr> <tr> <td>Rated current:</td> <td>13.3-13.8 A</td> </tr> <tr> <td>Rated current at 3/4 load:</td> <td>11 A</td> </tr> <tr> <td>Rated current at 1/2 load:</td> <td>9.5 A</td> </tr> <tr> <td>Starting current:</td> <td>87 A</td> </tr> <tr> <td>Rated current at no load:</td> <td>8.3 A</td> </tr> <tr> <td>Cos phi - power factor:</td> <td>0.74</td> </tr> <tr> <td>Cos phi - p.f. at no load:</td> <td>0.1</td> </tr> <tr> <td>Cos phi - p.f. at 3/4 load:</td> <td>0.65</td> </tr> <tr> <td>Cos phi - p.f. at 1/2 load:</td> <td>0.52</td> </tr> <tr> <td>Rated speed:</td> <td>1455 rpm</td> </tr> <tr> <td>Locked-rotor torque:</td> <td>98 Nm</td> </tr> <tr> <td>Breakdown torque:</td> <td>122 Nm</td> </tr> <tr> <td>Moment of inertia:</td> <td>0.1721 kg m²</td> </tr> <tr> <td>Motor efficiency at full load:</td> <td>83.9 %</td> </tr> <tr> <td>Motor efficiency at 3/4 load:</td> <td>83.3 %</td> </tr> <tr> <td>Motor efficiency at 1/2 load:</td> <td>81 %</td> </tr> <tr> <td>Number of poles:</td> <td>4</td> </tr> <tr> <td>Start. method:</td> <td>star/delta</td> </tr> <tr> <td>Enclosure class (IEC 34-5):</td> <td>IP68</td> </tr> <tr> <td>Insulation class (IEC 85):</td> <td>F</td> </tr> <tr> <td>Explosion proof:</td> <td>no</td> </tr> <tr> <td>Length of cable:</td> <td>10 m</td> </tr> <tr> <td>Cable type:</td> <td>LYNIFLEX</td> </tr> <tr> <td>Type of cable plug:</td> <td>NO PLUG</td> </tr> <tr> <td colspan="2">Others:</td> </tr> <tr> <td>Net weight:</td> <td>165 kg</td> </tr> <tr> <td>Country of origin:</td> <td>HU</td> </tr> <tr> <td>Custom tariff no.:</td> <td>84137021</td> </tr> </table> | Max starts per. hour: | 20 | Rated current: | 13.3-13.8 A | Rated current at 3/4 load: | 11 A | Rated current at 1/2 load: | 9.5 A | Starting current: | 87 A | Rated current at no load: | 8.3 A | Cos phi - power factor: | 0.74 | Cos phi - p.f. at no load: | 0.1 | Cos phi - p.f. at 3/4 load: | 0.65 | Cos phi - p.f. at 1/2 load: | 0.52 | Rated speed: | 1455 rpm | Locked-rotor torque: | 98 Nm | Breakdown torque: | 122 Nm | Moment of inertia: | 0.1721 kg m ² | Motor efficiency at full load: | 83.9 % | Motor efficiency at 3/4 load: | 83.3 % | Motor efficiency at 1/2 load: | 81 % | Number of poles: | 4 | Start. method: | star/delta | Enclosure class (IEC 34-5): | IP68 | Insulation class (IEC 85): | F | Explosion proof: | no | Length of cable: | 10 m | Cable type: | LYNIFLEX | Type of cable plug: | NO PLUG | Others: | | Net weight: | 165 kg | Country of origin: | HU | Custom tariff no.: | 84137021 |
| Max starts per. hour: | 20 | | | | | | | | | | | | | | | | | | | | | | | | | | | | | | | | | | | | | | | | | | | | | | | | | | | | | | | | | | |
| Rated current: | 13.3-13.8 A | | | | | | | | | | | | | | | | | | | | | | | | | | | | | | | | | | | | | | | | | | | | | | | | | | | | | | | | | | |
| Rated current at 3/4 load: | 11 A | | | | | | | | | | | | | | | | | | | | | | | | | | | | | | | | | | | | | | | | | | | | | | | | | | | | | | | | | | |
| Rated current at 1/2 load: | 9.5 A | | | | | | | | | | | | | | | | | | | | | | | | | | | | | | | | | | | | | | | | | | | | | | | | | | | | | | | | | | |
| Starting current: | 87 A | | | | | | | | | | | | | | | | | | | | | | | | | | | | | | | | | | | | | | | | | | | | | | | | | | | | | | | | | | |
| Rated current at no load: | 8.3 A | | | | | | | | | | | | | | | | | | | | | | | | | | | | | | | | | | | | | | | | | | | | | | | | | | | | | | | | | | |
| Cos phi - power factor: | 0.74 | | | | | | | | | | | | | | | | | | | | | | | | | | | | | | | | | | | | | | | | | | | | | | | | | | | | | | | | | | |
| Cos phi - p.f. at no load: | 0.1 | | | | | | | | | | | | | | | | | | | | | | | | | | | | | | | | | | | | | | | | | | | | | | | | | | | | | | | | | | |
| Cos phi - p.f. at 3/4 load: | 0.65 | | | | | | | | | | | | | | | | | | | | | | | | | | | | | | | | | | | | | | | | | | | | | | | | | | | | | | | | | | |
| Cos phi - p.f. at 1/2 load: | 0.52 | | | | | | | | | | | | | | | | | | | | | | | | | | | | | | | | | | | | | | | | | | | | | | | | | | | | | | | | | | |
| Rated speed: | 1455 rpm | | | | | | | | | | | | | | | | | | | | | | | | | | | | | | | | | | | | | | | | | | | | | | | | | | | | | | | | | | |
| Locked-rotor torque: | 98 Nm | | | | | | | | | | | | | | | | | | | | | | | | | | | | | | | | | | | | | | | | | | | | | | | | | | | | | | | | | | |
| Breakdown torque: | 122 Nm | | | | | | | | | | | | | | | | | | | | | | | | | | | | | | | | | | | | | | | | | | | | | | | | | | | | | | | | | | |
| Moment of inertia: | 0.1721 kg m ² | | | | | | | | | | | | | | | | | | | | | | | | | | | | | | | | | | | | | | | | | | | | | | | | | | | | | | | | | | |
| Motor efficiency at full load: | 83.9 % | | | | | | | | | | | | | | | | | | | | | | | | | | | | | | | | | | | | | | | | | | | | | | | | | | | | | | | | | | |
| Motor efficiency at 3/4 load: | 83.3 % | | | | | | | | | | | | | | | | | | | | | | | | | | | | | | | | | | | | | | | | | | | | | | | | | | | | | | | | | | |
| Motor efficiency at 1/2 load: | 81 % | | | | | | | | | | | | | | | | | | | | | | | | | | | | | | | | | | | | | | | | | | | | | | | | | | | | | | | | | | |
| Number of poles: | 4 | | | | | | | | | | | | | | | | | | | | | | | | | | | | | | | | | | | | | | | | | | | | | | | | | | | | | | | | | | |
| Start. method: | star/delta | | | | | | | | | | | | | | | | | | | | | | | | | | | | | | | | | | | | | | | | | | | | | | | | | | | | | | | | | | |
| Enclosure class (IEC 34-5): | IP68 | | | | | | | | | | | | | | | | | | | | | | | | | | | | | | | | | | | | | | | | | | | | | | | | | | | | | | | | | | |
| Insulation class (IEC 85): | F | | | | | | | | | | | | | | | | | | | | | | | | | | | | | | | | | | | | | | | | | | | | | | | | | | | | | | | | | | |
| Explosion proof: | no | | | | | | | | | | | | | | | | | | | | | | | | | | | | | | | | | | | | | | | | | | | | | | | | | | | | | | | | | | |
| Length of cable: | 10 m | | | | | | | | | | | | | | | | | | | | | | | | | | | | | | | | | | | | | | | | | | | | | | | | | | | | | | | | | | |
| Cable type: | LYNIFLEX | | | | | | | | | | | | | | | | | | | | | | | | | | | | | | | | | | | | | | | | | | | | | | | | | | | | | | | | | | |
| Type of cable plug: | NO PLUG | | | | | | | | | | | | | | | | | | | | | | | | | | | | | | | | | | | | | | | | | | | | | | | | | | | | | | | | | | |
| Others: | | | | | | | | | | | | | | | | | | | | | | | | | | | | | | | | | | | | | | | | | | | | | | | | | | | | | | | | | | | |
| Net weight: | 165 kg | | | | | | | | | | | | | | | | | | | | | | | | | | | | | | | | | | | | | | | | | | | | | | | | | | | | | | | | | | |
| Country of origin: | HU | | | | | | | | | | | | | | | | | | | | | | | | | | | | | | | | | | | | | | | | | | | | | | | | | | | | | | | | | | |
| Custom tariff no.: | 84137021 | | | | | | | | | | | | | | | | | | | | | | | | | | | | | | | | | | | | | | | | | | | | | | | | | | | | | | | | | | |

96047613 SE1.80.80.55.4.51D.B 50 Hz

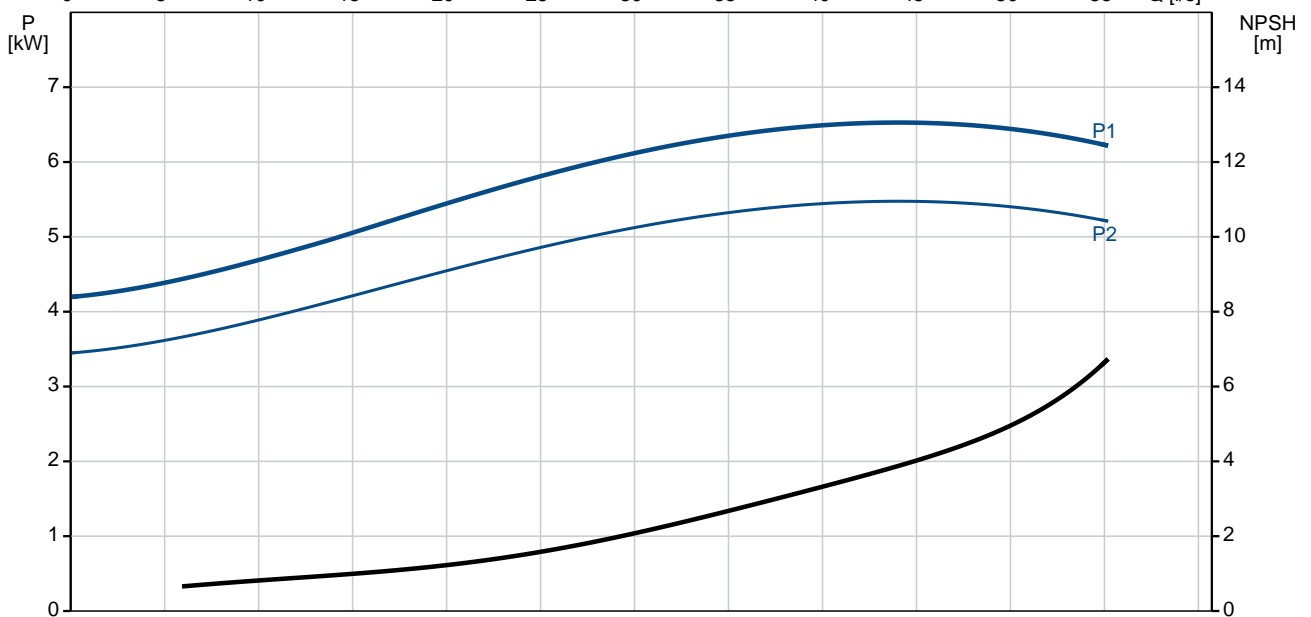
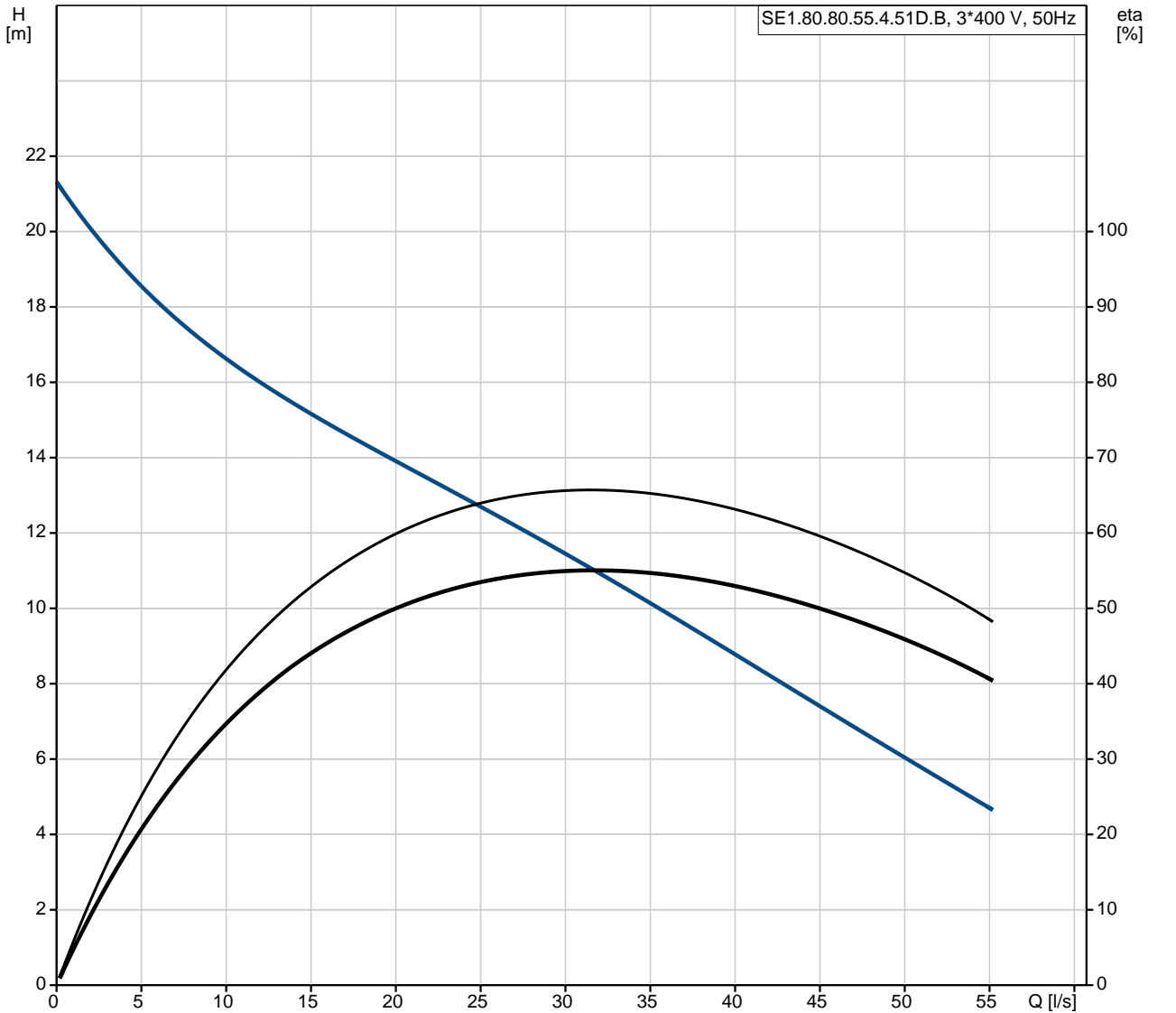

| Description | Value |
|--------------------------------|--------------------------|
| General information: | |
| Product name: | SE1.80.80.55.4.51D.B |
| Product No: | 96047613 |
| EAN number: | 5700395053661 |
| | 5700395053661 |
| Price: | 4.486,00 GBP |
| Technical: | |
| Max flow: | 55.3 l/s |
| Head max: | 21.2 m |
| Type of impeller: | S-TUBE |
| Maximum particle size: | 80 mm |
| Primary shaft seal: | SIC/SIC |
| Secondary shaft seal: | CARBON/CERAMICS |
| Max. hydraulic efficiency: | 68 % |
| Approvals on nameplate: | EN12050-1 |
| Curve tolerance: | ISO9906:2012 3B2 |
| Cooling jacket: | with cooling jacket |
| Materials: | |
| Pump housing: | EN 1561 EN-GJL-250 |
| Impeller: | Cast iron |
| Installation: | |
| Maximum operating pressure: | 6 bar |
| Flange standard: | DIN |
| Pump outlet: | DN 80 |
| Pressure rating: | PN 10 |
| Maximum installation depth: | 20 m |
| Inst dry/wet: | DRY/SUBMERGED |
| Installation: | horizontal or vertical |
| Liquid: | |
| Pumped liquid: | Any Newtonian liquid |
| Liquid temperature range: | 0 .. 40 °C |
| Density: | 998.2 kg/m ³ |
| Electrical data: | |
| Power input - P1: | 6.5 kW |
| Rated power - P2: | 5.5 kW |
| Mains frequency: | 50 Hz |
| Rated voltage: | 3 x 380-415 V |
| Voltage tolerance: | +6/-10 % |
| Max starts per. hour: | 20 |
| Rated current: | 13.3-13.8 A |
| Rated current at 3/4 load: | 11 A |
| Rated current at 1/2 load: | 9.5 A |
| Starting current: | 87 A |
| Rated current at no load: | 8.3 A |
| Cos phi - power factor: | 0.74 |
| Cos phi - p.f. at no load: | 0.1 |
| Cos phi - p.f. at 3/4 load: | 0.65 |
| Cos phi - p.f. at 1/2 load: | 0.52 |
| Rated speed: | 1455 rpm |
| Locked-rotor torque: | 98 Nm |
| Breakdown torque: | 122 Nm |
| Moment of inertia: | 0.1721 kg m ² |
| Motor efficiency at full load: | 83.9 % |
| Motor efficiency at 3/4 load: | 83.3 % |
| Motor efficiency at 1/2 load: | 81 % |
| Number of poles: | 4 |
| Start. method: | star/delta |
| Enclosure class (IEC 34-5): | IP68 |

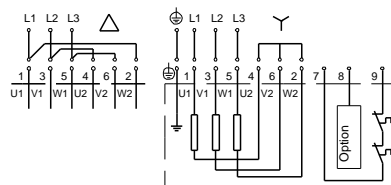
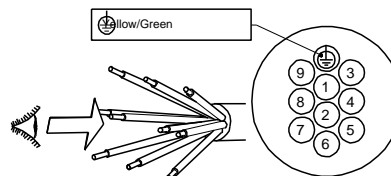
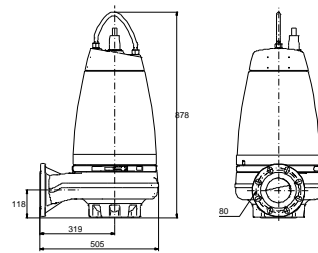
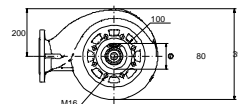
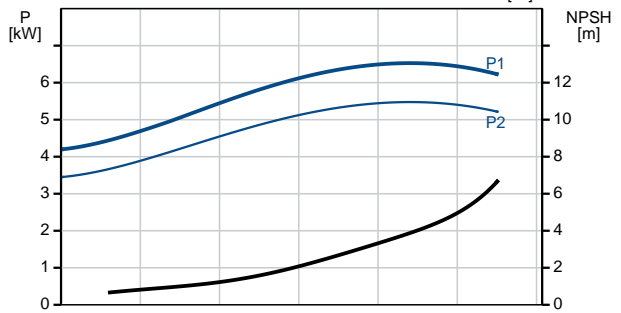
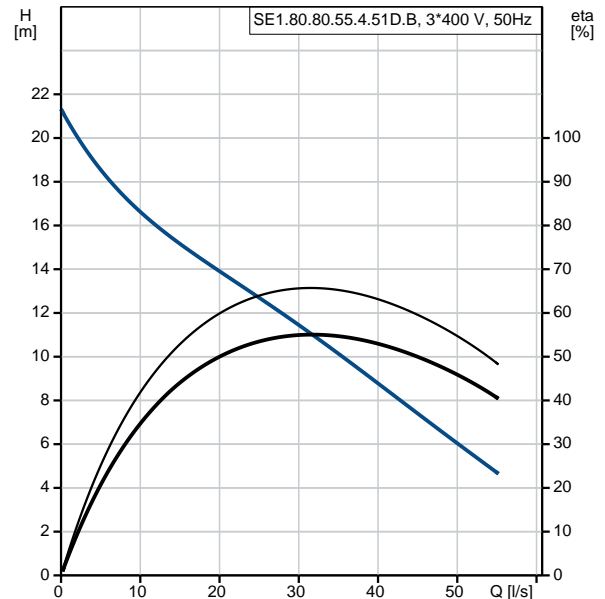



Company name:

Created by:

Phone:

Date:

21/01/2020

| Description | Value |
|----------------------------|-----------------------------|
| Insulation class (IEC 85): | F |
| Explosion proof: | no |
| Motor protec: | THERMAL SWITCH |
| Thermal protec: | internal |
| Length of cable: | 10 m |
| Cable type: | LYNIFLEX |
| Type of cable plug: | NO PLUG |
| Controls: | |
| Control box: | not included |
| Moisture sensor: | without moisture sensors |
| Water-in-oil sensor: | without water-in-oil sensor |
| Temp. sensor: | N |
| Others: | |
| Net weight: | 165 kg |
| Country of origin: | HU |
| Custom tariff no.: | 84137021 |

96047613 SE1.80.80.55.4.51D.B 50 Hz

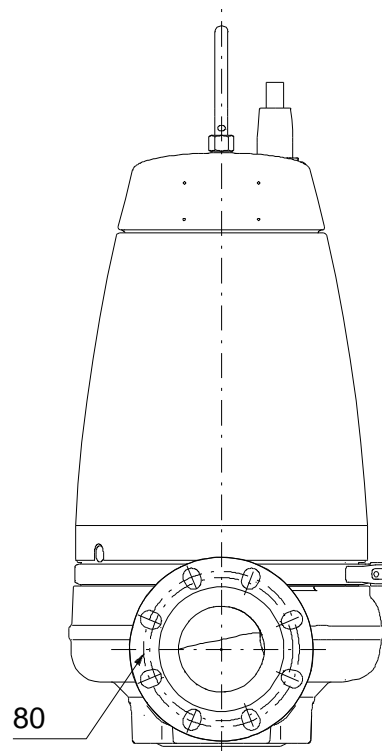
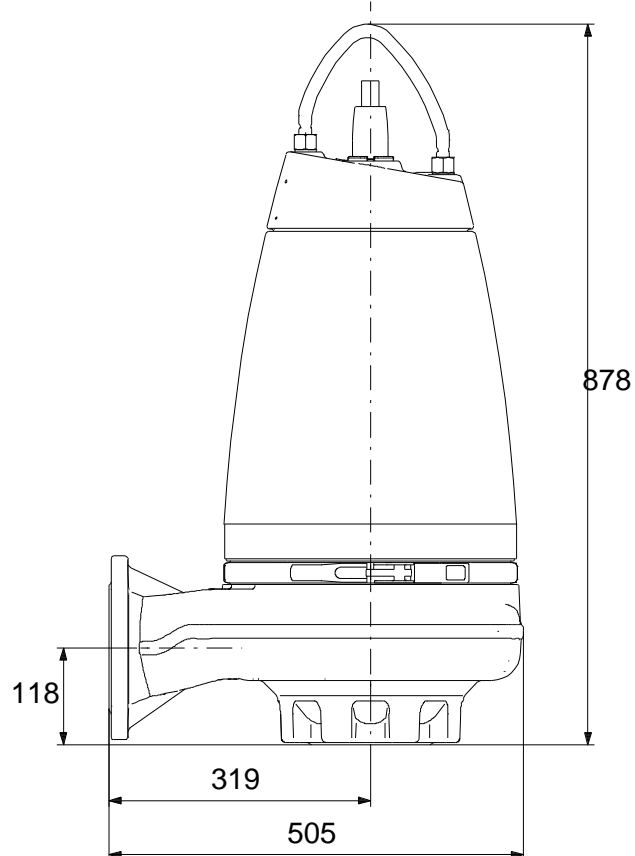
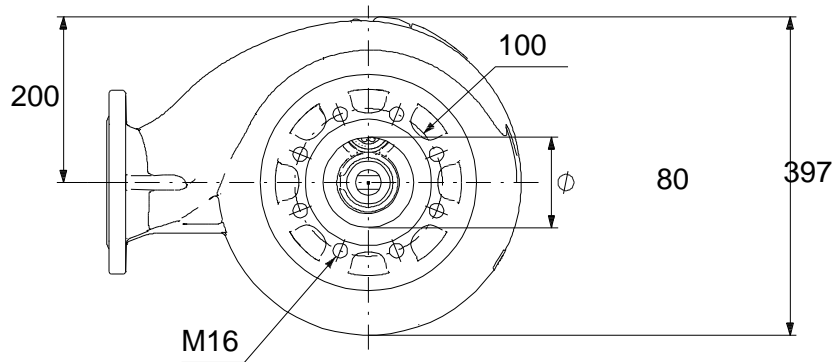

Note! All units are in [mm] unless others are stated.
Disclaimer: This simplified dimensional drawing does not show all details.

96047613 SE1.80.80.55.4.51D.B 50 Hz

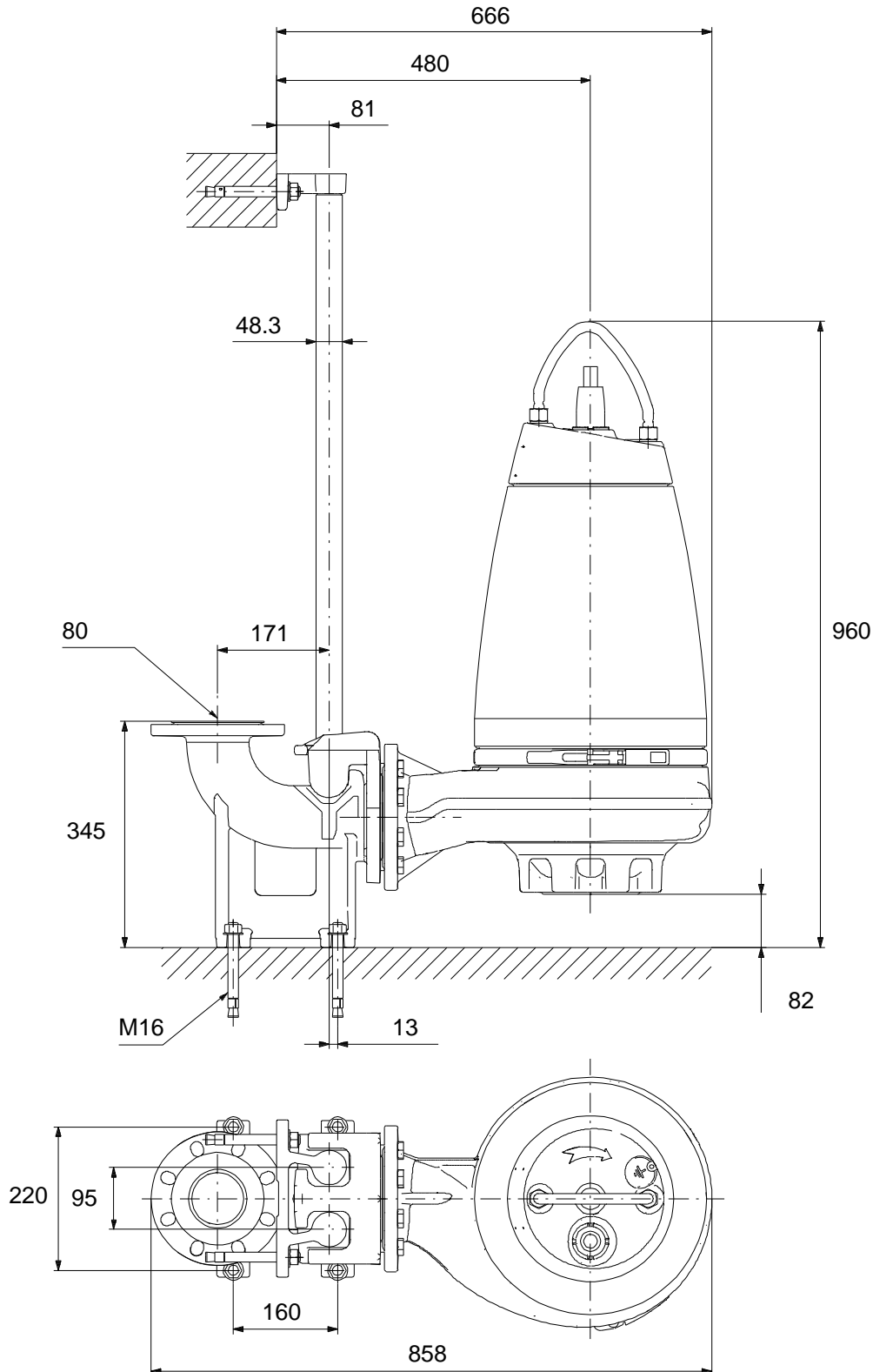

Note! All units are in [mm] unless others are stated.
Disclaimer: This simplified dimensional drawing does not show all details.

96047613 SE1.80.80.55.4.51D.B 50 Hz

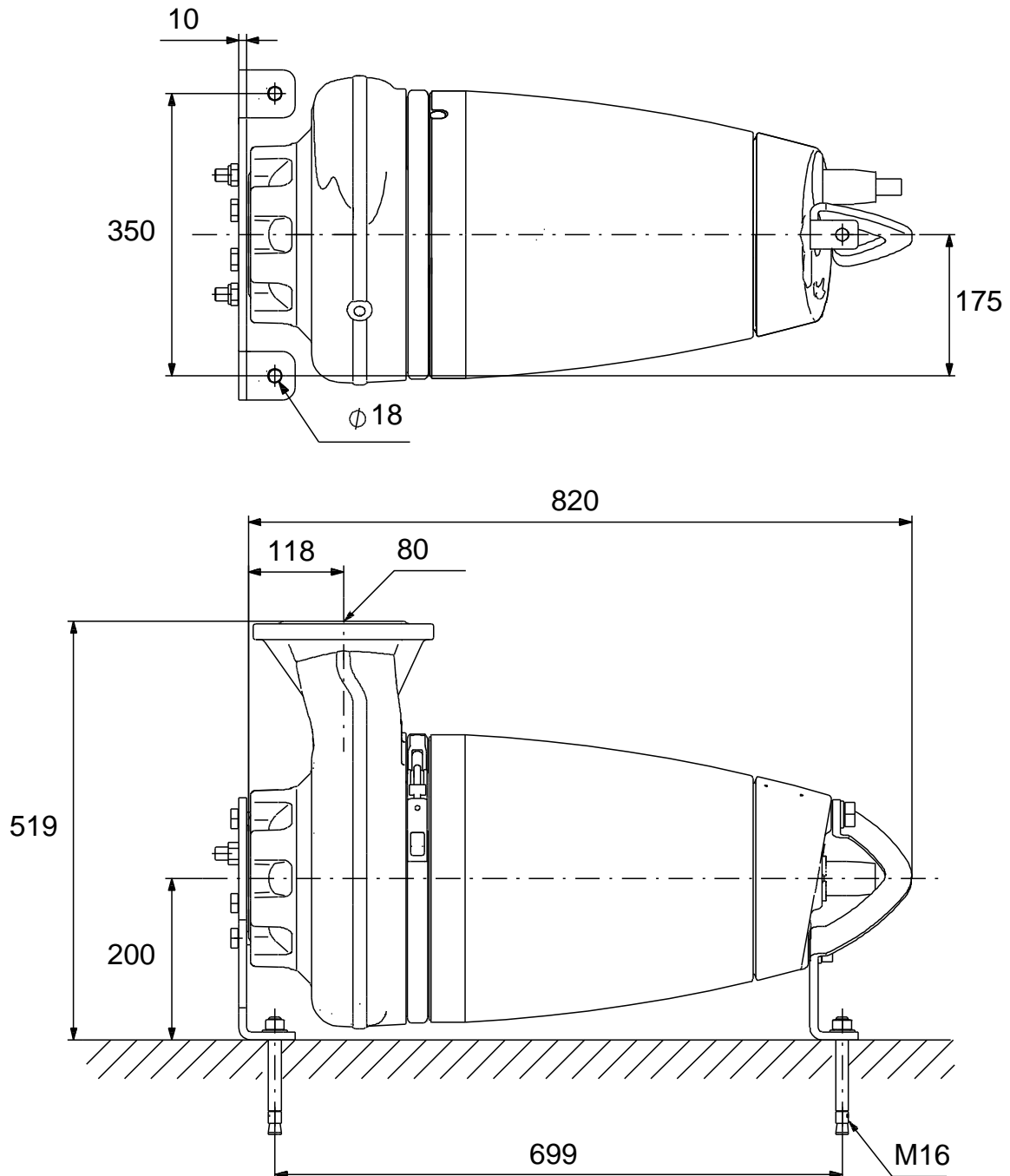

Note! All units are in [mm] unless others are stated.
Disclaimer: This simplified dimensional drawing does not show all details.

96047613 SE1.80.80.55.4.51D.B 50 Hz

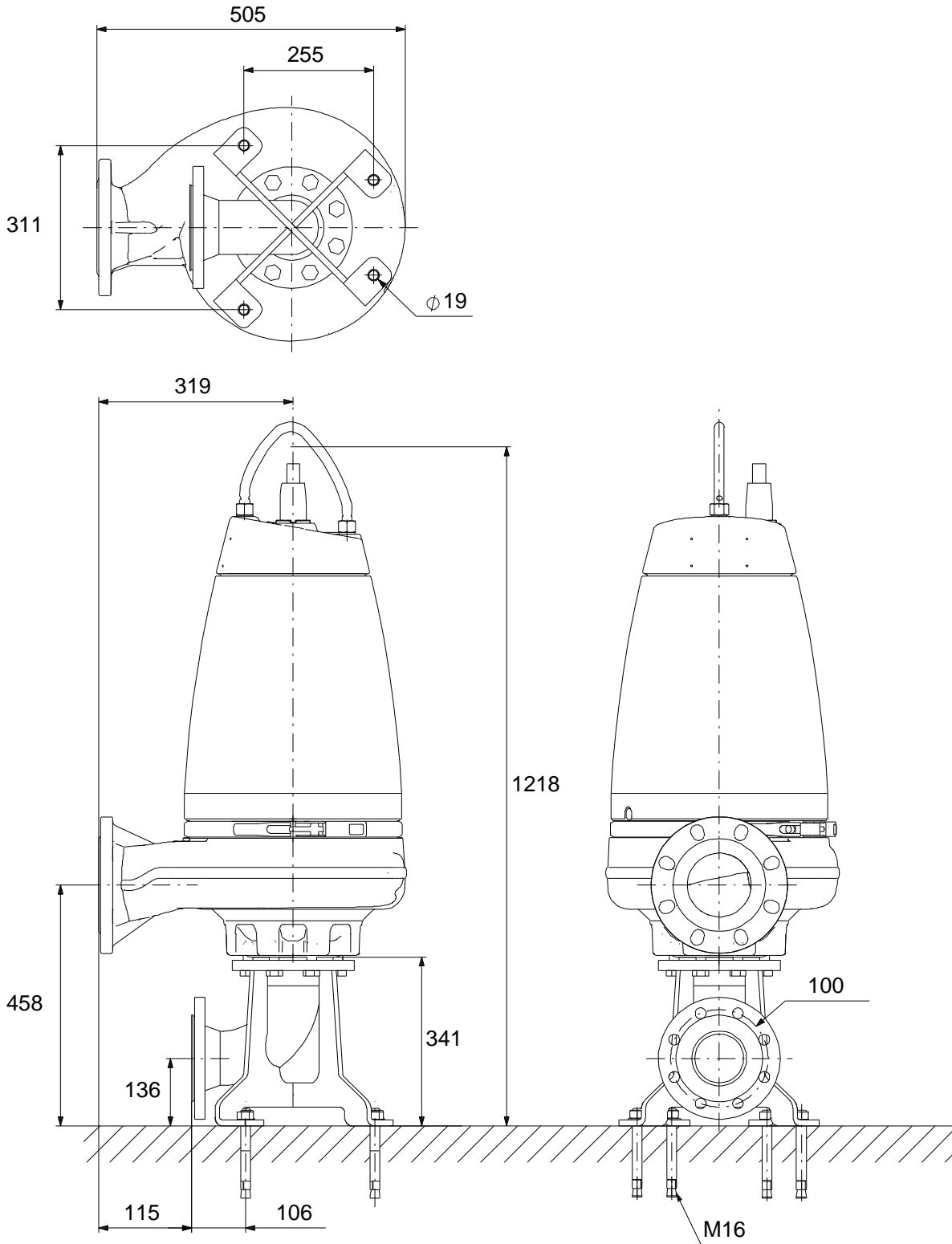

Note! All units are in [mm] unless others are stated.
Disclaimer: This simplified dimensional drawing does not show all details.

96047613 SE1.80.80.55.4.51D.B 50 Hz

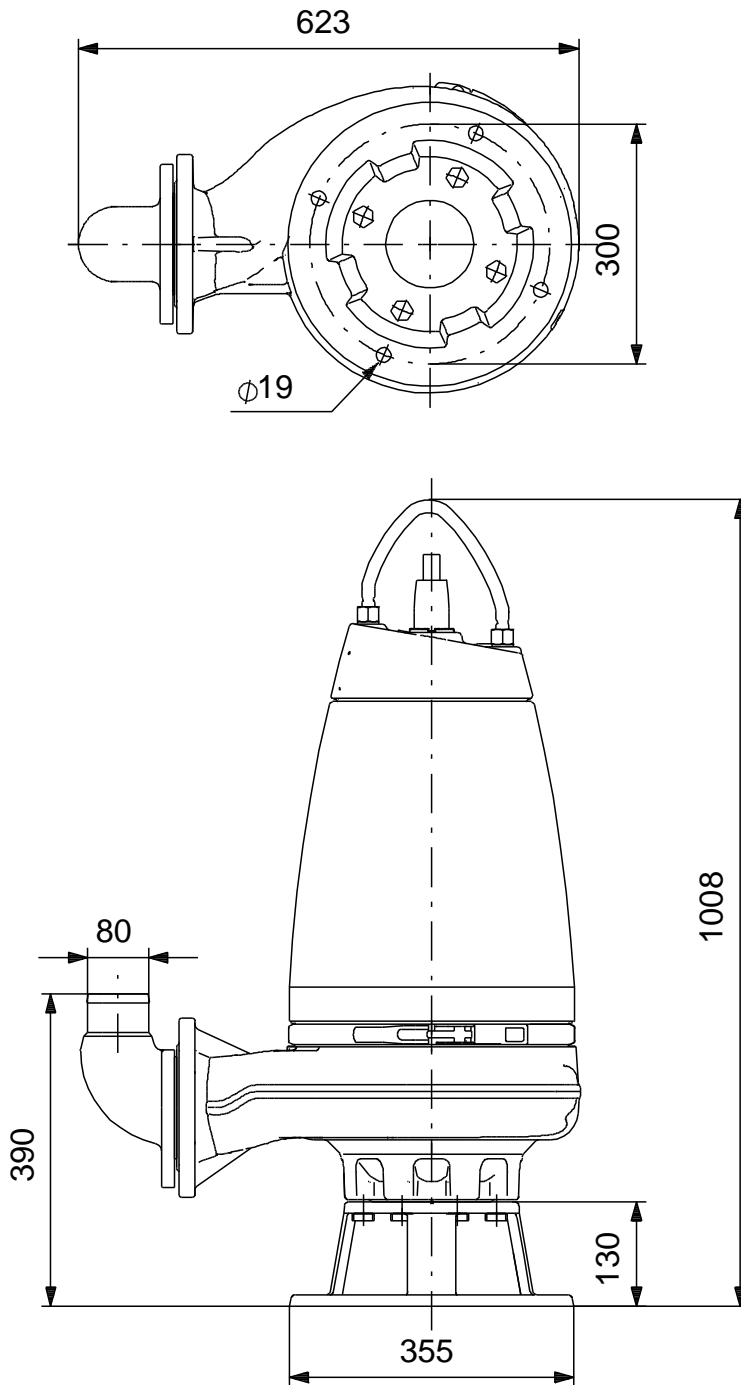

Note! All units are in [mm] unless others are stated.
Disclaimer: This simplified dimensional drawing does not show all details.