

3SCD7/09/5 C L05

Technical data	Company name	
	Contact	
	Phone number	
	e-mail address	

Operating data				
1	Pumpe type	Single head pump	Fluid	Water, pure
2	No. of pumps	1	Operating temperature t A	°C 4
3	Nominal flow	m³/h 0	pH-value at t A	7
4	Nominal head	m 0	Density at t A	kg/m³ 1000
5	Static head	m 0	Kin. viscosity at t A	mm²/s 1.569
6	Inlet pressure	kPa 0	Vapor pressure at t A	kPa 100
7	Environmental temperature	°C 20	Solids	0
8	Available system NPSH	m 0	Altitude	m 0

Pump data				
9	Design	Borehole pumps		
10	Execution		Impeller Ø	Max. mm 0
11	Operating speed	rpm 2900	designed	mm
12	Number of stages	7	Min.	mm 0
13	Suction nozzle	protected by strainer	Nominal	m³/h ()
14	Discharge nozzle	/	Flow	Max- m³/h 4.2
15	Max. casing pressure	kPa	Min-	m³/h 1.2
16	Max. working pressure	kPa 757.7	Head	Nominal m
17	Impeller type		at Qmax	m 27.4
18	Head H(Q=0)	m 77	at Qmin	m 68.6
19	Max. shaft power	kW 1	Shaft power	kW ()
20	Total weight	kg 16.5	Efficiency	%
21			NPSH 3%	m

Materials				
22		Pump		
23	Head	Stainless steel / ASTM A743 CF8	Upper head	Technopolymer
24	Capacitor	-	Upper bearing support	Stainless steel / AISI 304
25	Connection container	PA66-GF25	Sleeve with wound stator	Stainless steel / AISI 304
26	Motor shaft	Stainless steel / AISI 431	Internal mech. seal (rotary part)	Carbographite
27	Lower bearing support	Die-cast aluminium	Internal mech. seal (fixed part)	Steatite
28	Lower head	Technopolymer	External mech. seal	Silicon carbide / Silicon carbide / NBR
29	Final bowl	Stainless steel / AISI 304	Pump shaft	Stainless steel / AISI 431
30	Diffuser	Stainless steel / AISI 304	Pump body	Stainless steel / AISI 304
31	Impeller	Technopolymer	Base	Aluminium
32	Elastomers	Nitrile rubber (NBR)	Sleeve	Stainless steel / AISI 304
33	Capacitor housing spacer	PA66-GF25	PLUG	Stainless steel / AISI 304
34				
35				
36				
37				
38				
39				
40				
41				

Motor data				Cable	
42	Manufacturer	Type	MOT_3SC7/09/5	Cable type	
43	Specific design	Single phase pump motor		Cable cross section	mm²
44	Rated power	0.9 kW	Phases	1	Environmental temperature °C 20
45	Corrected motor power	0.9 kW	No. starts / h	max. 20	cable length m
46	coolant speed	min.	Weight	0 kg	
47	Rated current	5.88 A	Electric voltage	230 V	
48	Reduced current	5.88 A	Starting mode	Directly	
49	Degree of protection	IP 68	Speed	2850 rpm	
50	motor connection		Installation		

Remarks				

Project	Project ID	Created by Joshua Harvey	Created on 04-07-21	Last update 04-07-21
---------	------------	-----------------------------	------------------------	-------------------------

3SCD7/09/5 C L05

Performance curve

Company name
Contact
Phone number
e-mail address

	Ø mm	Pump capacity			Pump head		Shaft power P2			Frequency	Hz	50
		Operating range Min. m³/h	Max. m³/h	η Max. m³/h	H(Q=0) m	η Max. m	P2(Q=0) kW	Max. kW	η Max. kW	Operating speed	rpm	2900
actual	0	1.2	4.2	2.94	77.2	47.6		0.993	0.985	Nominal flow	m³/h	0
Min.	0	/	/	2.94	77.2	47.6		/	0.985	Nominal head	m	0
Max.	0	/	/	2.94	77.2	47.6		/	0.985	Inlet pressure	kPa	0
										Static head	m	0

Power datas referred to:

hydr. Performance acceptance acc. To EN ISO 9906 Class Grade

Water, pure [100%] ; 4°C; 1000kg/m³; 1.57mm²/s

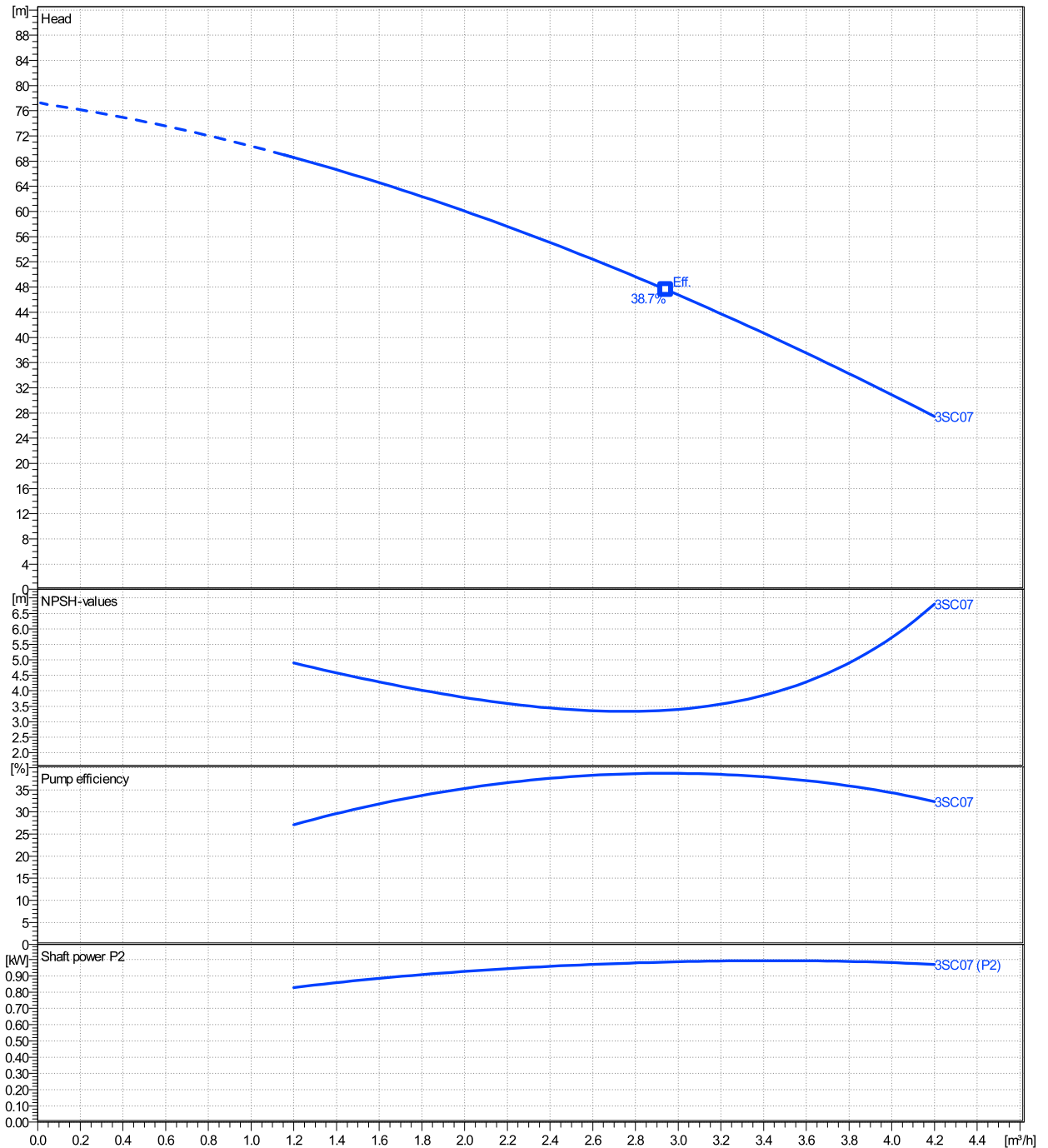

Project	Project ID	Created by Joshua Harvey	Created on 04-07-21	Last update 04-07-21
---------	------------	-----------------------------	------------------------	-------------------------

3SCD7/09/5 C L05

Dimensions

Company name
Contact
Phone number
e-mail address

Standard

Single phase pump motor
MOT_3SC7/09/5

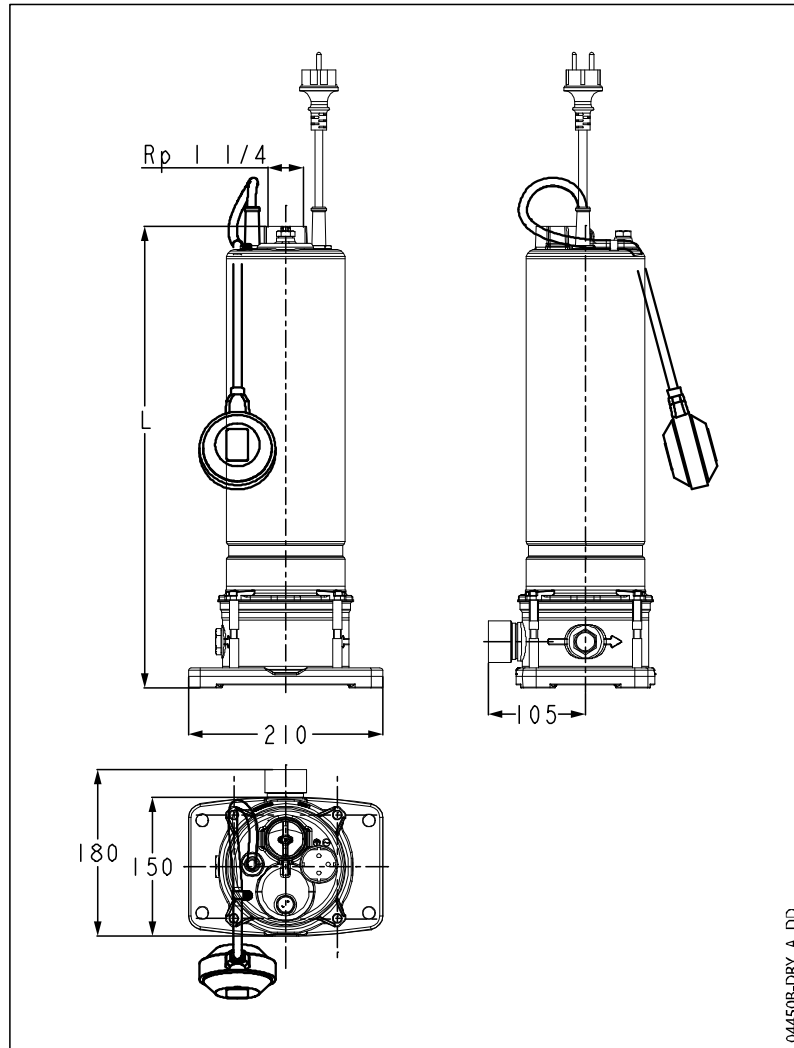

Dimensions [mm]	
L	578
Weight (+/- 5%) [kg]	
Pump	17 kg
Cable	
Motor	
Total weight	
Connections	
Suction nozzle protected by strainer	Discharge nozzle

Dimensions and weight without obligation

Project	Project ID	Created by Joshua Harvey	Created on 04-07-21	Last update 04-07-21
---------	------------	-----------------------------	------------------------	-------------------------