

Qty. Description1 **SPK 4-8/8 A-W-A-AUUV**

Note! Product picture may differ from actual product

Product No.: [39GH0308](#)

Multistage, immersible, self-priming, centrifugal pump for vertical and horizontal installation in tanks etc.

The pump has the following characteristics:

- Installation length according to DIN 5440.
- Impellers, intermediate chambers and spline shaft are made of stainless steel and motor stool of GG 20.
- Mechanical shaft seal according to EN 12756.
- Power transmission via cast iron split coupling.

The motor is a 3-phase AC motor.

Immersion depth: 287 mm

Liquid:

Pumped liquid: Water
Liquid temperature range: -10 .. 90 °C
Selected liquid temperature: 20 °C
Density at selected liquid temperature: 998.2 kg/m³

Technical:

Pump speed on which pump data are based: 2856 rpm
Rated flow: 4 m³/h
Rated head: 25 m
Primary shaft seal: AUUV
Curve tolerance: ISO9906:2012 3B
Drain holes: Open drain hole

Materials:

Pump head: Cast iron
EN-GJL-200
ASTM 25B
Impeller: Stainless steel
DIN W.-Nr. 1.4301
AISI 304

Installation:

Maximum ambient temperature: 40 °C
Pipe connection: G 3/4
Flange size for motor: FT85

Electrical data:

Motor type: 71B
IE Efficiency class: IE3

Qty.	Description
------	-------------

Rated power - P2:	0.55 kW
Power (P2) required by pump:	0.55 kW
Mains frequency:	50 Hz
Rated voltage:	3 x 220-240D/380-415Y V
Rated current:	2.50/1.44 A
Starting current:	580-620 %
Cos phi - power factor:	0.80-0.70
Rated speed:	2830-2850 rpm
Efficiency:	IE3 77,8%
Motor efficiency at full load:	77.8 %
Motor efficiency at 3/4 load:	81.5 %
Motor efficiency at 1/2 load:	79.5 %
Number of poles:	2
Enclosure class (IEC 34-5):	55 Dust/Jetting
Insulation class (IEC 85):	F
Motor No:	85805103

Others:

Minimum efficiency index, MEI :	N/A
Net weight:	10.7 kg
Gross weight:	12 kg
Danish VVS No.:	385644008
Country of origin:	HU
Custom tariff no.:	84137075

39GH0308 SPK 4-8/8 A-W-A-AUUV 50 Hz

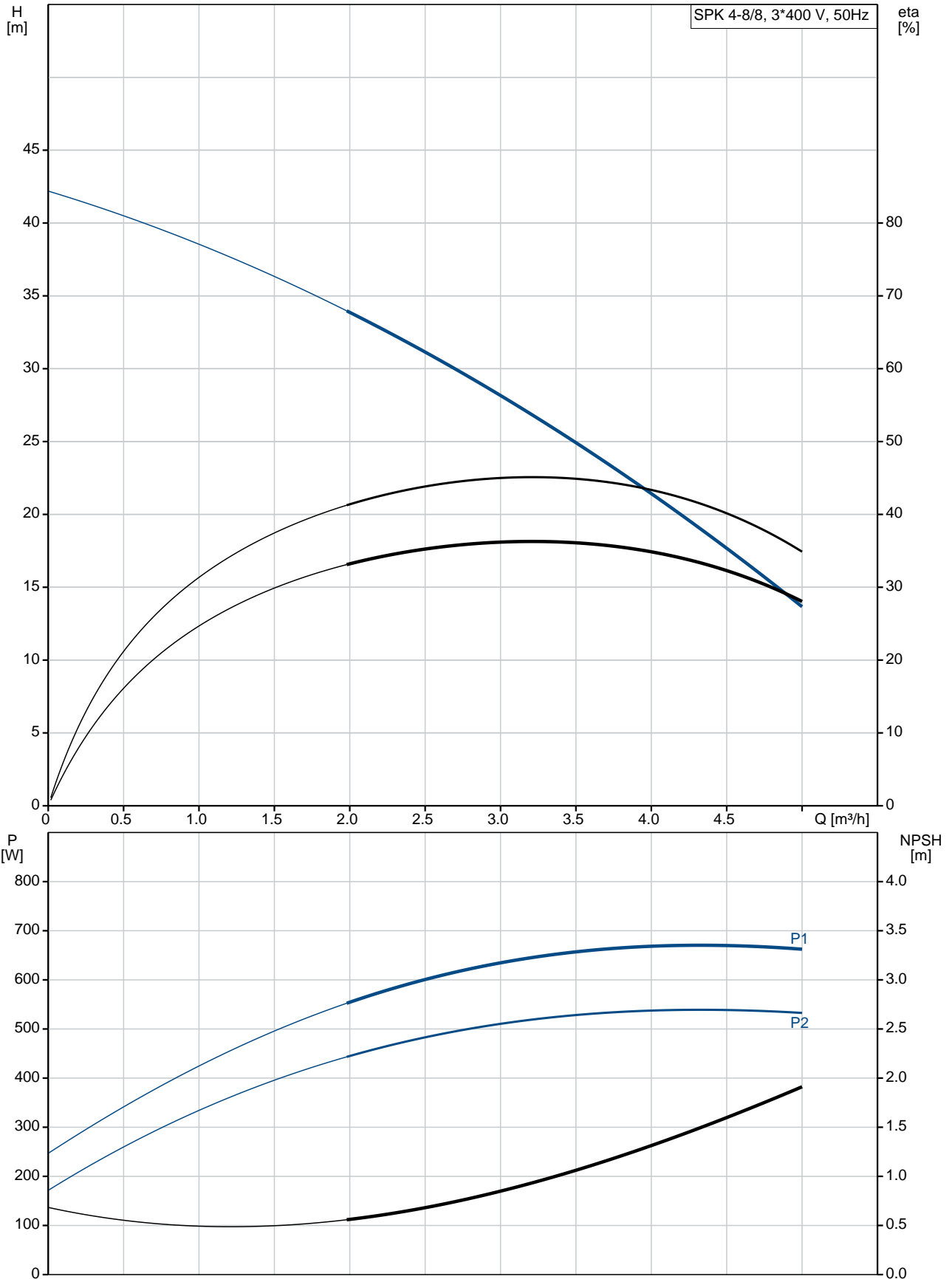

Description	Value
General information:	
Product name:	SPK 4-8/8 A-W-A-AUUV
Product No:	39GH0308
EAN number:	5708601062551 5708601062551
Price:	751,00 GBP
Technical:	
Pump speed on which pump data are based:	2856 rpm
Rated flow:	4 m ³ /h
Rated head:	25 m
Stages:	8
Impellers:	8
Primary shaft seal:	AUUV
Curve tolerance:	ISO9906:2012 3B
Pump version:	A
Model:	E
Drain holes:	Open drain hole
Materials:	
Pump head:	Cast iron EN-GJL-200 ASTM 25B
Impeller:	Stainless steel DIN W.-Nr. 1.4301 AISI 304
Material code:	A
Installation:	
Maximum ambient temperature:	40 °C
Pipe connection:	G 3/4
Flange size for motor:	FT85
Connect code:	W
Liquid:	
Pumped liquid:	Water
Liquid temperature range:	-10 .. 90 °C
Selected liquid temperature:	20 °C
Density at selected liquid temperature:	998.2 kg/m ³
Electrical data:	
Motor type:	71B
IE Efficiency class:	IE3
Rated power - P2:	0.55 kW
Power (P2) required by pump:	0.55 kW
Mains frequency:	50 Hz
Rated voltage:	3 x 220-240D/380-415Y V
Rated current:	2.50/1.44 A
Starting current:	580-620 %
Cos phi - power factor:	0.80-0.70
Rated speed:	2830-2850 rpm
Efficiency:	IE3 77,8%
Motor efficiency at full load:	77.8 %
Motor efficiency at 3/4 load:	81.5 %
Motor efficiency at 1/2 load:	79.5 %
Number of poles:	2
Enclosure class (IEC 34-5):	55 Dust/Jetting
Insulation class (IEC 85):	F
Motor protec:	NONE
Motor No:	85805103
Others:	

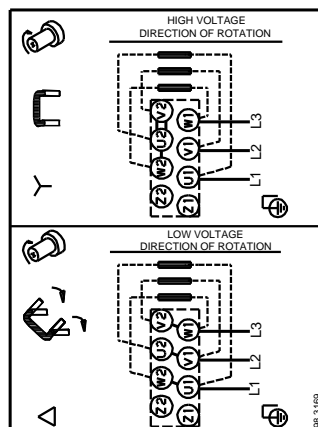
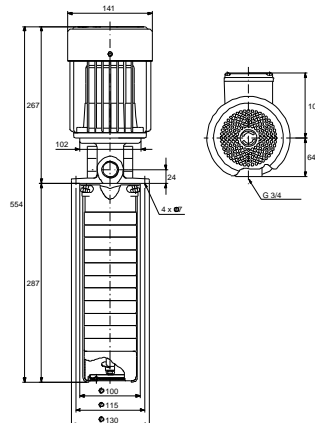
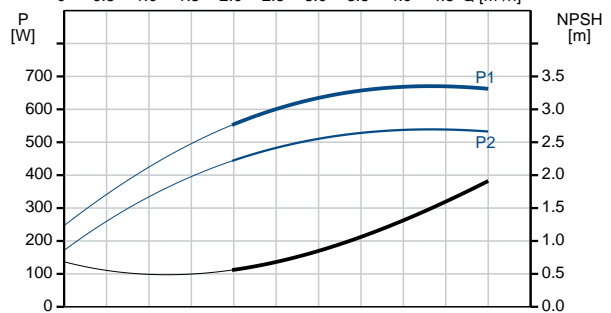
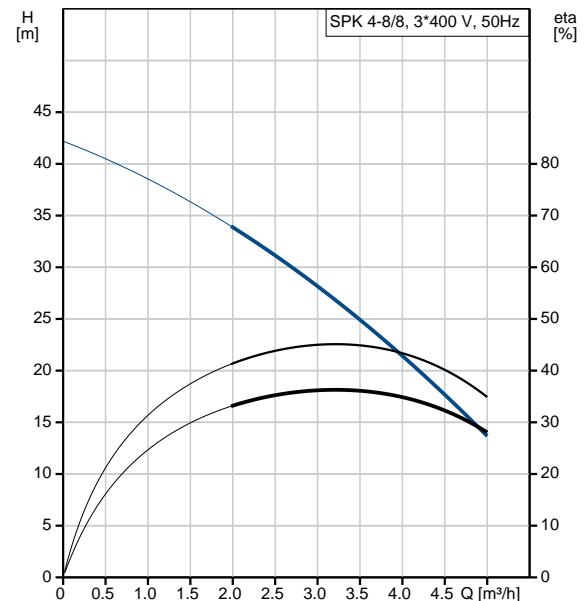



Company name:

Created by:

Phone:

Date:

15/10/2019

Description	Value
Minimum efficiency index, MEI :	N/A
Net weight:	10.7 kg
Gross weight:	12 kg
Danish VVS No.:	385644008
Country of origin:	HU
Custom tariff no.:	84137075