

12A01910 SP 17-10 50 Hz

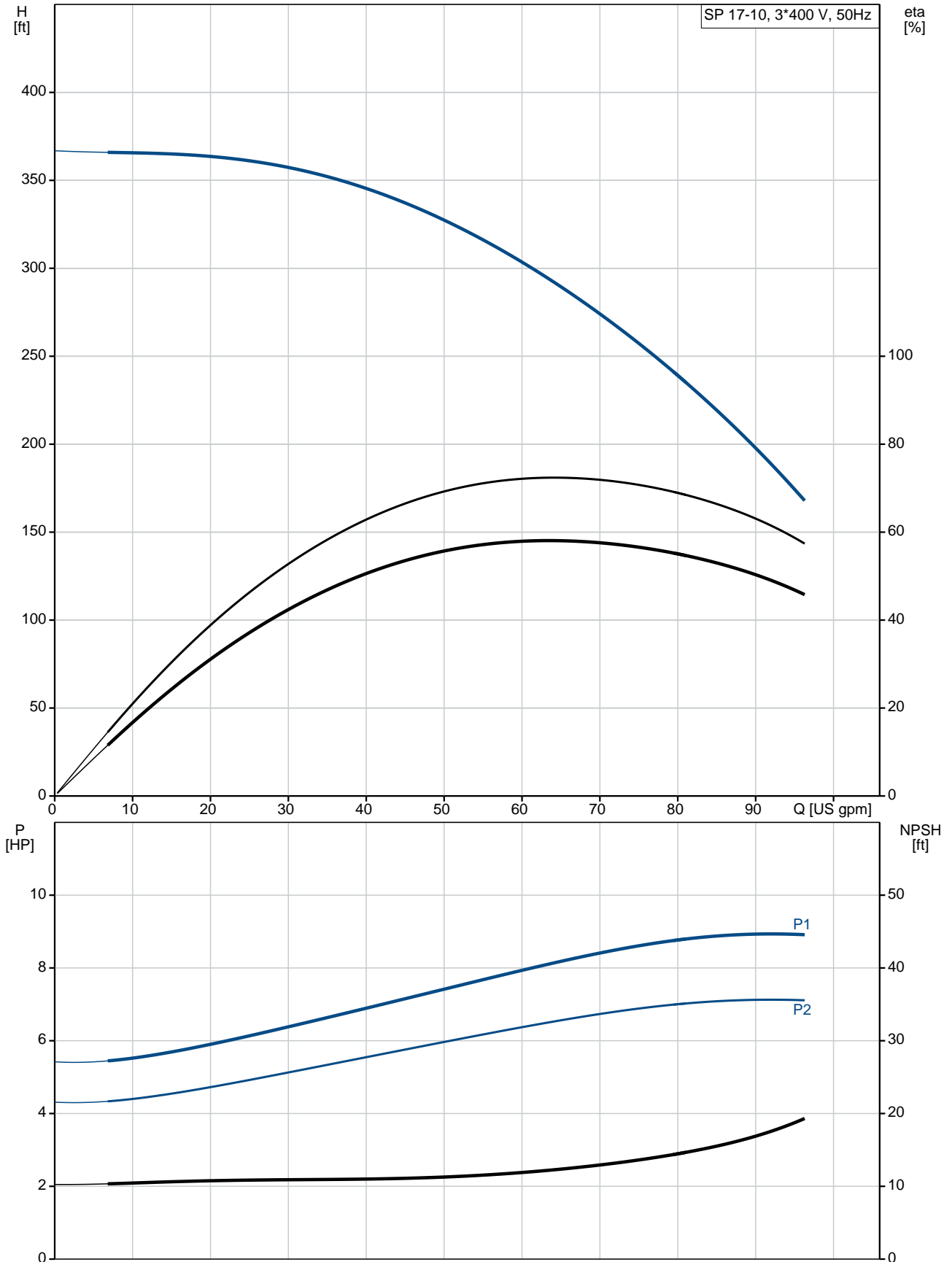

Description	Value
General information:	
Product name:	SP 17-10
Product No.:	12A01910
EAN:	5700391131202
Technical:	
Pump speed on which pump data is based:	2900 rpm
Rated flow:	74.8 US gpm
Rated head:	265.8 ft
Stages:	10
Impeller reduc.:	NONE
Shaft seal for motor:	HM/CER
Approvals on nameplate:	CE,EAC
Curve tolerance:	ISO9906:2012 3B
Model:	B
Valve:	YES
Motor version:	T40
Materials:	
Pump:	Stainless steel EN 1.4301 AISI 304
Impeller:	Stainless steel EN 1.4301 AISI 304
Motor:	Stainless steel DIN W.-Nr. 1.4301 AISI 304
Installation:	
Pump outlet:	RP2 1/2
Motor diameter:	4 inch
Liquid:	
Pumped liquid:	Water
Maximum liquid temperature:	104 °F
Max liquid temperature at 0.15 m/sec:	104 °F
Selected liquid temperature:	68 °F
Density:	62.29 lb/ft³
Electrical data:	
Motor type:	MS4000
Applic. motor:	GRUNDFOS
Rated power - P2:	7.5 HP
Power (P2) required by pump:	7.5 HP
Main frequency:	50 Hz
Rated voltage:	3 x 380-400-415 V
Rated current:	13.0-13.0-13.4 A
Starting current:	480-530-550 %
Cos phi - power factor:	0.85-0.81-0.76
Rated speed:	2850-2860-2870 rpm
Start. method:	direct-on-line
Enclosure class (IEC 34-5):	IP68
Insulation class (IEC 85):	F
Motor protection:	NONE
Thermal protec:	external
Built-in temperature transmitter:	yes
Motor Number:	79195511
Others:	
Minimum efficiency index, MEI :	0.70
ErP status:	EuP Standalone/Prod.
Net weight:	98.1 lb

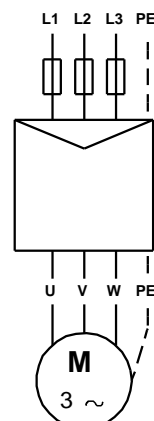

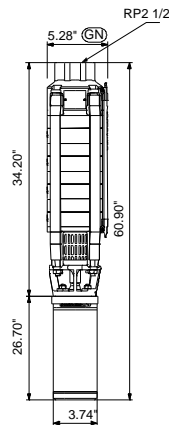
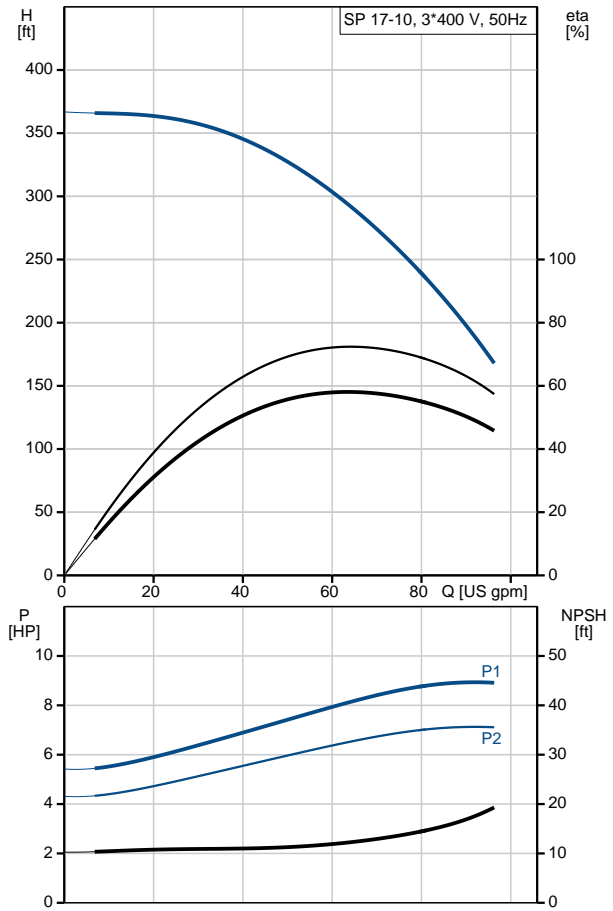

Company name:

Created by:

Phone:

Date:

6/17/2019

Description	Value
Gross weight:	154 lb
Shipping volume:	7.06 ft ³
Danish VVS No.:	388336100

12A01910 SP 17-10 50 Hz

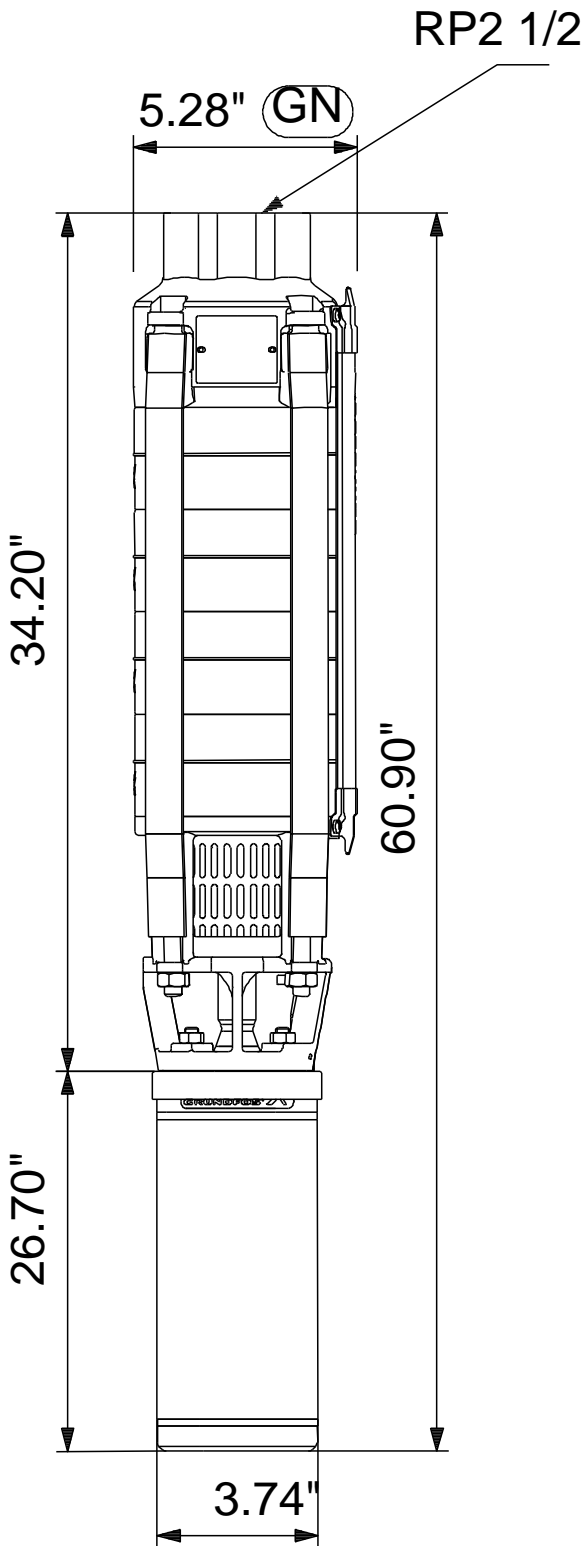

Note! All units are in [in] unless otherwise stated.
Disclaimer: This simplified dimensional drawing does not show all details.

12A01910 SP 17-10 50 Hz

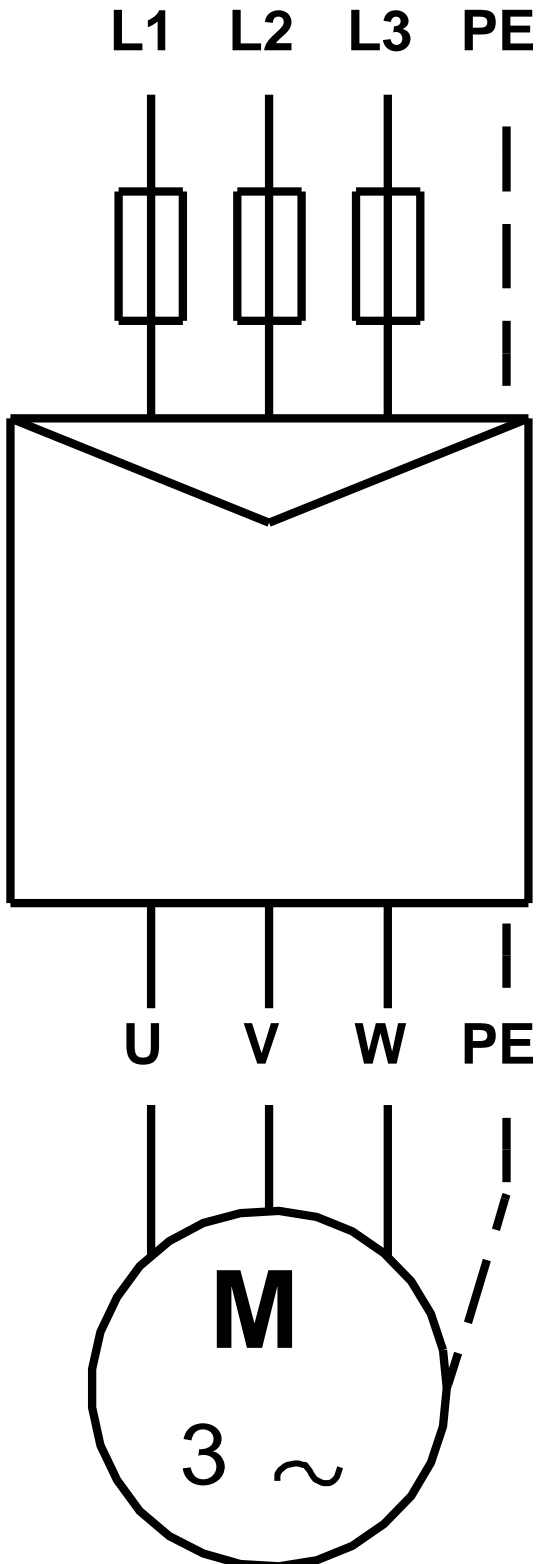

All units are [in] unless otherwise presented.



Company name:

Created by:

Phone:

Date: 6/17/2019

Order Data:

Product name: SP 17-10

Amount: 1

Product No.: 12A01910

Total: Price on request
